

Owner's manual

# *SPORTCLASSIC*

***GT1000***

***GT1000 TOURING***



# ***SPORTCLASSIC***

***GT1000***

***GT1000 TOURING***



We would like to welcome you among Ducati enthusiasts, and congratulate you on your excellent choice of motorcycle. We are sure that you will use your Ducati for longer journeys as well as short daily trips, but however you use your motorcycle, Ducati Motor Holding s.p.a wishes you an enjoyable ride.

We are continuously working to improve our Technical Assistance service. For this reason, we recommend that you follow strictly the instructions in this manual, especially those regarding the running-in period. In this way, you can be sure your Ducati motorcycle will continue to be a pleasure to ride.

For repairs or advice, please contact one of our authorized service centres.

We also provide an information service for all Ducati owners and enthusiasts for any advice and suggestions you might need.

Enjoy the ride!



## Notes

Ducati Motor Holding S.p.A. cannot accept any liability for errors that may have occurred in the preparation of this manual. All information in the manual is valid at the time of going to print. Ducati Motor Holding S.p.A. reserves the right to make any modifications required due to the ongoing development of their products.

For safety and reliability, to avoid invalidating the warranty and to maintain the value of your motorcycle, use only original Ducati spare parts.



## Warning

This manual is an integral part of the product and, if ownership is transferred to a third party, must always be passed to the new owner.

# Table of contents

## General indications 6

- Warranty 6
- Symbols 6
- Useful road safety information 7
- Riding with a full load 8
- Identification data 9

## Controls 10

- Position of the motorcycle controls 10
- Instrument panel 11
- LCD functions 13
- The immobilizer system 16
- Keys 16
- Code card 17
- Procedure to override the immobilizer using the throttle twistgrip 18
- Duplicate keys 19
- Ignition switch and steering lock 20
- Left-hand handlebar switch 21
- Clutch lever 22
- Right-hand handlebar switch 23
- Throttle twistgrip 23
- Front brake lever 24
- Rear brake pedal 25

- Gearchange pedal 25
- Adjusting the position of the gearchange and rear brake pedals 26

## Main components and devices 28

- Position on motorcycle 28
- Fuel tank filler cap 29
- Seat lock and helmet holder 30
- Sidestand 32
- Rear shock absorber adjusters 33

## Riding the motorcycle 34

- Running-in recommendations 34
- Pre-ride checks 35
- Starting the engine 36
- Moving off 38
- Braking 38
- Stopping the motorcycle 39
- Parking 39
- Refuelling 40
- Toolkit and accessories 41

## Main Maintenance Operations 42

- Checking the brake and clutch fluid level 42
- Checking the brake pads for wear 44
- Lubricating cables and joints 45
- Adjusting the throttle cable 46
- Charging the battery 47
- Tensioning the drive chain 49

Lubricating the drive chain 50  
 Changing light bulbs 51  
 Front turn signals 53  
 Rear turn signals 54  
 Number plate light 55  
 Brake light 56  
 Headlight aim 57  
 Tyres 58  
 Checking the engine oil level 60  
 Cleaning and renewing the spark plugs 61  
 General cleaning 62  
 Storing the motorcycle 63  
 Important notes 63

## Maintenance 64

Programmed maintenance plan: operations to be carried out  
 be the dealer 64  
 Programmed maintenance plan: operations to be carried out  
 be the customer 67

## Technical data 68

Dimensions GT 1000 (mm) 68  
 Weights 68  
 Dimensions GT 1000 Touring (mm) 69  
 Weights 69  
 Engine 71  
 Timing system 71  
 Performance data 72  
 Brakes 72  
 Transmission 73  
 Frame 74

Wheels 74  
 Tyres 74  
 Spark plugs 74  
 Fuel system 75  
 Suspension 75  
 Exhaust system 75  
 Available colours 75  
 Electrical system 76

## Routine maintenance record 80

## For United States of America Version Only 81

Reporting of safety defects 81  
 Safety warnings 81  
 Noise emission warranty 81  
 Noise and exhaust emission control system information 81  
 Tampering warning 82  
 Riding safety 83  
 Protective apparel 84  
 Vehicle identification number (VIN) 84  
 Label location 85  
 California evaporation emission system 88  
 Ducati limited warranty on emission control system 88

## Routine maintenance record 91

## General indications

### Warranty

For your own safety, to ensure the continuing reliability of your motorcycle and to avoid the risk of invalidating the warranty, we strongly recommend that you contact a Ducati Dealer or Authorized Service Centre for any operations that require professional servicing expertise. Our highly skilled staff have the tools required to perform any servicing job to the highest professional standards, using only Ducati original spare parts to ensure full interchangeability, smooth running and long life.

All Ducati motorcycles come with a Warranty Booklet. However, the warranty does not apply to motorcycles used in competitions. If any motorcycle part is tampered with, modified, or replaced with parts other than original Ducati spare parts during the warranty period, the warranty is automatically invalidated.

### Symbols

Ducati Motor Holding S.p.A. advises you to read this manual carefully so as to become familiar with your motorcycle. If in doubt, please contact a Ducati Dealer or Authorized Service Centre. You will find the information in the manual useful on trips (which Ducati Motor Holding S.p.A. hopes will be smooth and enjoyable), and it will help you obtain top performance from your motorcycle for a long time. This booklet uses a set of symbols with special meanings:



#### Warning

Failure to comply with these instructions may put you at risk, and lead to severe injury or even death.



#### Important

Possibility of causing damage to the motorcycle and/or its components.



#### Notes

Additional information about the current operation.

References to the RIGHT or LEFT side of the motorcycle assume you are sitting on the seat, facing forward.

## Useful road safety information



### Warning

Read this section before riding your motorcycle.

Many accidents are the result of the inexperience of the rider. Always make sure you have your licence with you; you need a valid licence that entitles you to ride a motorcycle.

Do not lend your motorcycle to persons who are inexperienced or do not hold a valid licence.

Riders and passengers must ALWAYS wear appropriate clothing and a safety helmet.

Do not wear loose clothes or accessories that could become tangled in the controls or limit your field of vision.

Never start or run the engine in enclosed space.

Exhaust gases are poisonous and may lead to loss of consciousness or even death within a short time.

The rider should keep his/her feet on the footrests when the motorcycle is in motion.

In order to be prepared for any change of direction or variations in the road surface, ALWAYS hold the handlebars firmly with both hands. The pillion passenger should ALWAYS hold on to the seat strap with both hands.

Obey the legal requirements and observe national and local regulations.

Always respect speed limits where these are indicated.

However, ALWAYS adapt your speed to suit the current visibility, road and traffic conditions.

ALWAYS indicate in good time when you intend to turn or change lane, using the turn indicators.

Be sure you are clearly visible and avoid riding within the blind spot of a vehicle in front of you.

Be very careful at road junctions, or when riding in areas near exits from private land or car parks, or on the slip roads to motorways.

ALWAYS turn off the engine when refuelling. Be extremely careful not to spill fuel on the engine or on the exhaust pipe when refuelling.

Do not smoke when refuelling.

While refuelling, you may inhale noxious fuel vapours.

Should any fuel drops be spilled on your skin or clothing, immediately wash with soap and water and change your clothing.

ALWAYS remove the key if leaving your motorcycle unattended.

The engine, exhaust pipes, and silencers remain hot for a long time.



### Warning

The exhaust system may still be hot even after engine is switched off; so take special care not to touch it with any part of the body and do not park the motorcycle next to inflammable material (wood, leaves, etc.).

Park your motorcycle where no one is likely to knock against it, and use the sidestand.

Never park on uneven ground or soft terrain or the motorcycle may fall over.



## Riding with a full load

Your motorcycle is designed for travelling over long distances with a full load in complete safety.

Even weight distribution is critical for maintaining safety standards, and to avoid getting into difficulties when making sudden manoeuvres or riding on bumpy roads.

## Information on load capacity

The total weight of the motorcycle in running order including rider, passenger, luggage and additional accessories, should not exceed 390 kg.

Arrange your luggage or heavy accessories in the lowest possible position and as close to centre of the motorcycle as possible.

Secure the luggage firmly to the motorcycle structure. Luggage incorrectly secured may cause the motorcycle to become unstable.

Never attach bulky or heavy objects to the top yoke or front mudguard, as this would cause dangerous instability.

Do not insert objects into gaps in the frame, where they could interfere with moving parts.

Check that the tyres are inflated to the pressure indicated on page 58 and that they are in good condition.

## Identification data

All Ducati motorcycles have two identification numbers, one for the frame (fig. 1) and one for the engine (fig. 2).

---

Frame number

---

---

Engine number

---



### Notes

These numbers indicate the motorcycle model and should be quoted when ordering spare parts.

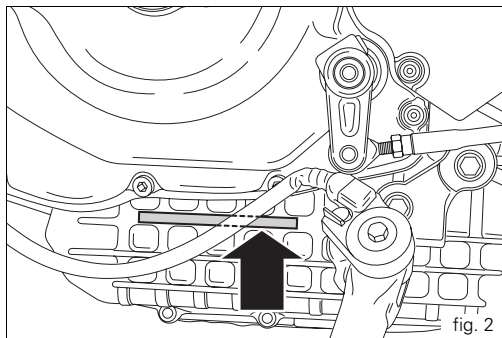
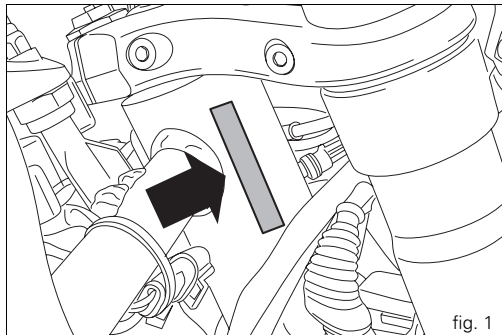

# Controls



## Warning

This section shows the position and function of the controls used to drive the motorcycle. Be sure to read this information carefully before you use the controls.

## Position of the motorcycle controls (fig. 3)

- 1) Instrument panel.
- 2) Key-operated ignition switch and steering lock.
- 3) LH handlebar switch.
- 4) Clutch lever.
- 5) RH handlebar switch.
- 6) Throttle twistgrip.
- 7) Front brake lever.
- 8) Gearchange pedal.
- 9) Rear brake pedal.

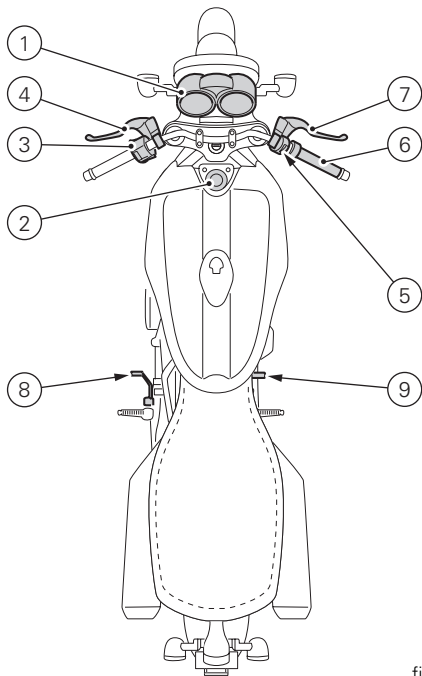





fig. 3

## Instrument panel (fig. 4.1 and fig. 4.2)

- 1) HIGH BEAM WARNING LIGHT  (BLUE).  
Illuminates when the high beam headlight is on.
- 2) TURN SIGNAL WARNING LIGHT  (GREEN).  
Flashes when a turn signal is on.
- 3) LOW FUEL WARNING LIGHT  (YELLOW).  
Illuminates when there are approximately 3.5 litres of fuel left in the tank.
- 4) NEUTRAL WARNING LIGHT (GREEN).  
Illuminates when the gearbox is in neutral.
- 5) ENGINE OIL PRESSURE WARNING LIGHT  (RED).  
Illuminates when engine oil pressure is too low. This light comes on when the ignition is switched to ON and should go out a few seconds after the engine starts. It may come on briefly if the engine is very hot, but should go out again as engine speed increases.

### Important

Do not use the motorcycle if this light stays on, otherwise the engine could be damaged.

### 6) AMBER WARNING LIGHT.

Comes on and flashes when the motorcycle is parked (immobilizer on); also used for immobilizer diagnostics.

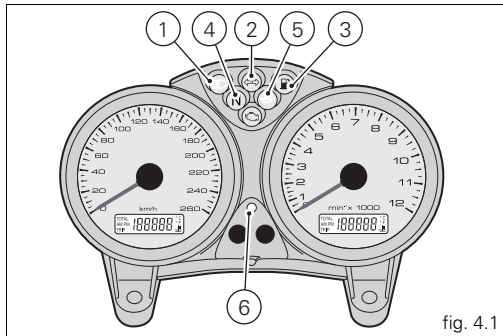

fig. 4.1



### Notes

When the immobilizer is activated, the light flashes for 24 hours after which it goes off, but the immobilizer remains active.

7) EOBD LIGHT  (YELLOW AMBER).

Comes on when the engine is locked. Switches off after a few seconds (normally 1.8 - 2 sec.).

8) SPEEDOMETER (km/h).

Indicates road speed.

a) LCD (1):

- ODOMETER (km).

Shows total distance travelled.

- TRIP METER (km).

Indicates the distance travelled since the meter was last reset or since illumination of the low fuel warning light (reserve).

- FUEL RESERVE TRIP METER.

When the fuel level warning light is on, displays the number of kilometres travelled in reserve.

9) TACHOMETER (rpm).

Indicates engine revs per minute.

b) LCD (2):

- CLOCK.

- OIL TEMPERATURE.

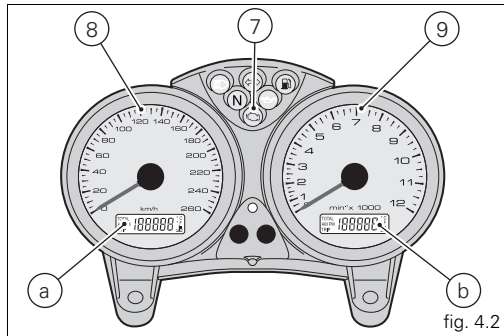

fig. 4.2

## LCD functions

When the engine is switched on (key turned from OFF to ON), the instrument panel checks all instruments (dials, display, warning lights), see (fig. 5 and fig. 6).

### LCD functions (1)

By pressing button (A, fig. 6) with the key turned to ON, you can cycle between display of the trip meter and the odometer and, if the fuel level warning light is on, the fuel reserve trip meter (latter function).

### Resetting the trip meter

If button (A, fig. 6) is held pressed for more than 2 seconds while the TRIP (trip meter) is active, the display is reset (LCD 1).

### LCD functions (2)

If button (B, fig. 6) is pressed with the ignition key at ON, the display shows the clock and the oil temperature.

### Setting the clock

Press (B, fig. 6) for at least 2 seconds and the time will be shown in display (2, fig. 6).

Select AM/PM by pressing button (A, fig. 6). Press button (B, fig. 6) to select the hour setting function. Press (A) repeatedly to change the hour indication. Press button (B) to change to the minute setting function. Press button (A) to increase the minutes; hold the button pressed for more than 5 seconds to increase the rate of change. Press button (B) to exit the clock setting function.

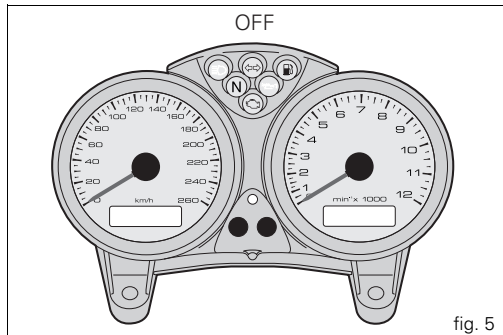

fig. 5

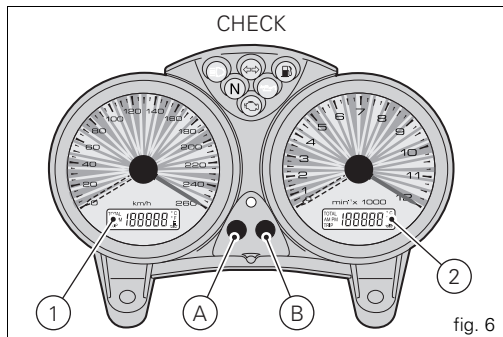

fig. 6

E

## Oil temperature function

If the oil temperature falls below 50 °C/122 °F, the message "LO" will appear on the display, and if it rises above 170 °C/338 °F "HI" will appear.

## Fuel level warning light

When the fuel level warning light the word "FUEL" will appear on display (2, fig. 6) and the fuel reserve trip meter function will be activated and indicate on display (1, fig. 6) the number of kilometres travelled in reserve preceded by the letter "F" (FUEL).

## Maintenance indicator function

The appearance of the message "MAInt" on the display (1, fig. 6) indicates that the recommended service interval has expired: this message will be displayed each time the key is turned to "ON" for a period of 5 seconds. When you see this message, you should contact your Ducati dealer or authorised service centre.

## Display backlight

Press button (B, fig. 6) within 5 seconds after the ignition key is turned to the ON position to adjust the brightness of the backlight. The brightness changes at each press of the button.



### Warning

Any adjustments to the instrument panel must only be carried out when the motorcycle is stationary. Never operate the instrument panel controls while riding the motorcycle.

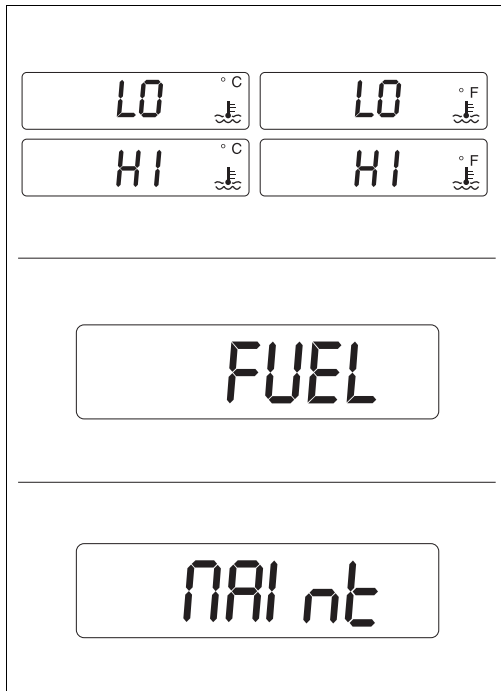

## Automatic headlight switch-off function

This function helps reduce battery use by automatically switching off the headlight.

The device is triggered in two cases:

- in the first case, if you turn the key from OFF to ON and do not start the engine, After 60 seconds the headlight will be turned on and will only turn on again the next time the key is turned from OFF to ON or the engine is started.
- in the second case, after normal use of the motorcycle with the lights on, if the engine is killed using the ENGINE STOP switch (1, fig. 13). In this case, 60 seconds after the engine is stopped, the headlight will be turned off and will only be turned on again the next time the engine is started.



### Notes

Also during engine starting, the system turns the headlight off and turns it back on once the engine has started.



## The immobilizer system

For additional anti-theft protection, the motorcycle is equipped with an IMMOBILIZER, an electronic system that locks the engine automatically whenever the ignition switch is turned off.

The handgrip of each ignition key contains an electronic device that modulates the output signal from a special antenna in the switch when the ignition is switched On. The modulated signal represents the “password” (which is changed at each start-up) by which the ECU recognizes the ignition key. The ECU will only allow the engine to start if it recognises this password.

### Keys (fig. 7)

The owner receives a set of keys, comprising:

- 1 key A (RED).

The red key is a service tool and is part of the motorcycle’s immobilizer system. It contains the code of the immobilizer system and should not be used for normal everyday use of your motorcycle. Your dealer may ask you to produce the red key in order to carry out certain service operations. For security reasons, the red key cannot be replaced.

In cases where the red key is required for servicing purposes and the owner is unable to produce it, it will be necessary to renew the motorcycle’s electronic control unit, instrument panel and ignition switch assembly, and the cost of these operations will be met by the owner. It is therefore important to keep the red key in a safe place.

- 2 keys B (BLACK).



## Warning

The red key (A) has a rubber sleeve to keep it in perfect condition, and prevent contact with other keys. Never remove this protection unless absolutely necessary.

The B keys are the keys for normal use, and are used to:

- start the engine;
- open the lock on the fuel tank filler cap;
- open the seat lock.

The A key performs all the same functions as the B keys and it can also be used to reset and re-program other black keys if necessary.

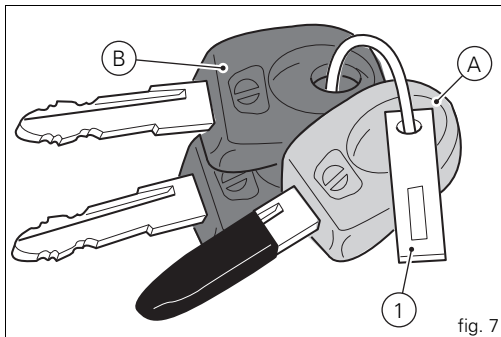

fig. 7



## Notes

The three keys are supplied attached to a small tag (1, fig. 7) bearing their identification number.



## Warning

Keep the keys separate, and store the tag (1, fig. 7) and key A in a safe place. It is also advisable to use only one of the black keys to start the motorcycle.

## Code card

The keys come with a CODE CARD (fig. 8), which shows: the electronic code (A, fig. 9) to be used if the engine is locked, and if the engine fails to start when the key is at ON.



## Warning

Keep the CODE CARD in a safe place. It is advisable to always carry the electronic code shown on the CODE CARD with you when using the motorcycle, in case it is necessary to override the engine immobilizer by means of the procedure that uses the throttle twistgrip.

In the event of faults in the immobilizer system, the following procedure makes it possible to disable the "engine lock" function, which is indicated by the yellow-amber EOBD warning light (7, fig. 4.1).

This operation is only possible with the electronic code shown on the code card.

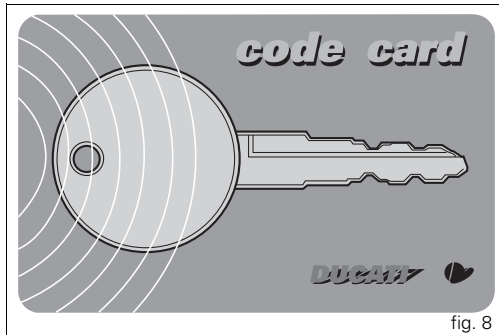

fig. 8

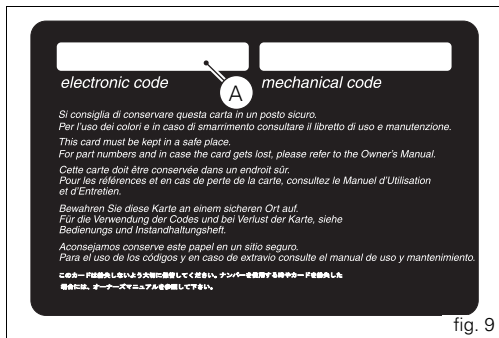

fig. 9

## Procedure to override the immobilizer using the throttle twistgrip

- 1) Turn the key to ON, turn the twistgrip to fully open the throttle and hold it open.  
The EOBD warning light (7, fig. 4.1) goes off after the pre-set time of 8 seconds.
- 2) Release the throttle as soon as the EOBD warning light turns off.
- 3) Now enter the electronic release code shown on the CODE CARD given to the customer when the motorcycle was handed over by the dealer. The EOBD warning light will light up and start flashing.  
Count the number of flashes of the EOBD (7, fig. 4.1) light equal to the first number of the secret code.  
Turn the throttle twistgrip to the fully open position:  
The digit entered is acknowledged, and the EOBD warning light comes on and stays on for the pre-set time of 4 seconds. If no operation is performed with the throttle twistgrip, the EOBD light will flash 20 times and then illuminate steadily. In this case, repeat the procedure from step (1).
- 4) Release the throttle as soon as the EOBD warning light turns off.
- 5) Repeat the operations in steps 3 and 4 until the last digit has been entered.
- 6) When you release the throttle, if the code was entered correctly, the EOBD light will flash to indicate that the engine is unlocked. The EOBD light returns to its normal state (off) after 4 seconds. If the code was NOT entered correctly, the EOBD light will remain lit and the procedure can be repeated as many times as necessary by turning the key to OFF, then re-starting from step (1).



## Notes

If the throttle twistgrip is released before the pre-set time, the EOBD light comes on again, and it will be necessary to turn the key to OFF and repeat the procedure from step (1).

## Operation

When the ignition key is turned from ON to OFF, the immobilizer system activates the engine lock. When the ignition key is turned from OFF to ON to start the engine:

- 1) if the code is recognised, the warning light (6, fig. 4.1) on the instrument panel will flash briefly. This means that the immobilizer system has recognised the code and disabled the engine lock. When you press the START (2, fig. 13) button, the engine will start up.
- 2) If either the warning light (6, fig. 4.1) or the EOBD light (7, fig. 4.1) remain lit, the code has not been recognized. In this case, it is advisable to turn the ignition key back to OFF and then to ON again. If the engine still does not start, try using another black key. If the engine still does not start, contact the DUCATI Service network.
- 3) If the warning light (6, fig. 4.1) keeps flashing, it means that an error signal from the immobilizer system has been cleared (e.g. with the override procedure using the throttle twistgrip). Turn the key to OFF and back to ON; the immobilizer light should return to its normal state (see step 1).



### Warning

Sharp knocks can damage the electronic components inside the key.

Always use the same key during the procedure. The use of different keys could prevent the system from recognizing the code in the inserted key.

## Duplicate keys

If you need additional keys, contact your DUCATI Service Centre with all the keys you have in your possession and your CODE CARD.

DUCATI Service will program new keys and re-program your original keys, up to a maximum of 8 keys.

DUCATI Service may ask for proof that you are the legitimate owner of the motorcycle.

The codes for any keys not present during the memory programming procedure are cancelled, to ensure that any keys that may have been lost can no longer be used to start the engine.



### Notes

If you sell your motorcycle, do not forget to give all keys and the CODE CARD to the new owner.

## Ignition switch and steering lock (fig. 10)

This is located in front of the fuel tank and has four positions:

- A) ON: enables lights and engine operation;
- B) OFF: disables lights and engine operation;
- C) LOCK: the steering is locked;
- D) P: sidelight and steering lock.



### Notes

To move the key to the last two positions, push it in before turning. The key can be removed in positions (B), (C) and (D).

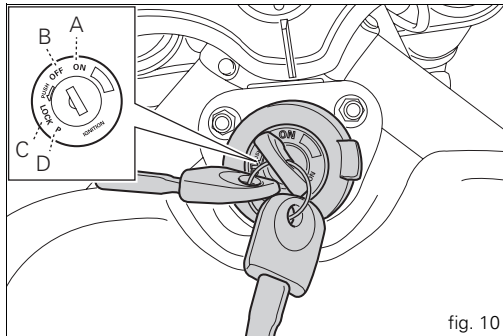







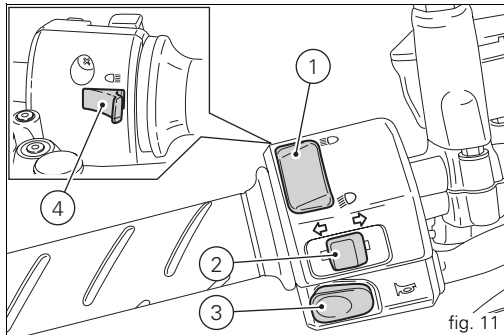

fig. 10

## Left-hand handlebar switch (fig. 11)

- 1) Two-position light selector switch:
  - position  = low beam headlight on;
  - position  = high beam headlight on.
- 2) Switch  = 3-position turn signal:
  - centre position = off;
  - position  = left turn;
  - position  = right turn.To switch off the indicator, press the lever once it has returned to the centre.
- 3) Button  = horn.
- 4) Button  = high beam flasher.



## Clutch lever (fig. 12)

The lever (1) disengages the clutch. The span adjuster (2) serves to alter the distance of the lever from the handlebar.

To make the adjustment, keep the lever (1) full forward and adjust the wheel (2), turning it to one of the four preset positions, taking account of the fact that:

position n° 1 corresponds to the maximum distance between the lever and grip, while position n° 4 corresponds to the minimum distance.

When the clutch lever (1) is operated, drive from the engine to the gearbox and the rear wheel is disengaged. Correct use of the clutch lever is very important in all riding situations, especially when moving off.



### Warning

Any adjustment of clutch and brake levers must only be carried out when motorcycle is stationary.



### Important

Using the clutch properly will prolong the life of the engine and prevent any damage to components in the transmission.



### Notes

The engine can be started with the sidestand down and the gearbox in neutral. If starting with a gear engaged, pull in the clutch lever (in this case the sidestand must be up).

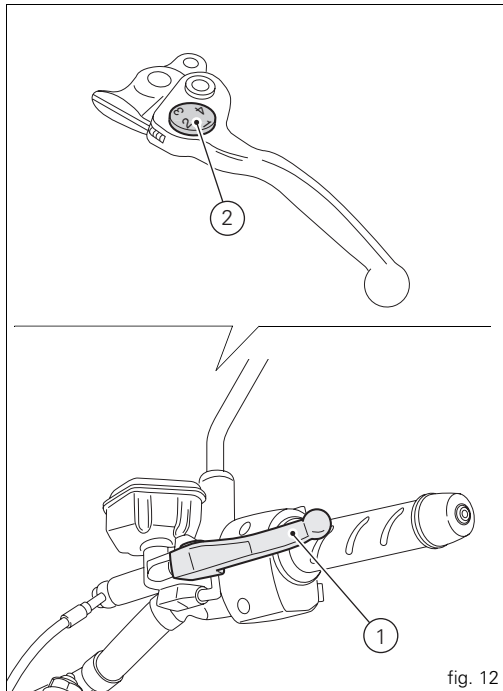





fig. 12

## Right-hand handlebar switch (fig. 13)

- 1) ENGINE STOP switch, with two positions:
- position  (RUN) = run;
  - position  (OFF) = stop engine.



### Warning

This switch is mainly intended for use in emergencies when you need to stop the engine quickly. After the engine is stopped, return the switch to position  to allow the motorcycle to be started again.



### Important

Riding with the headlight on, turning off the engine with the switch (1) and leaving the ignition in the ON position can drain the battery, as the light remains on.

- 2) Button  = engine start.

## Throttle twistgrip (fig. 13)

The twistgrip (3) on the right handlebar opens the butterfly valves in the throttle body. When released, the twistgrip returns automatically to the initial position (idling speed).

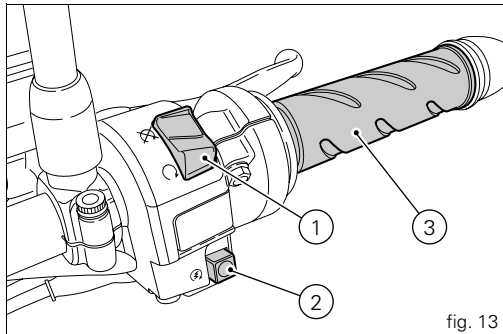



## Front brake lever (fig. 14)

Pull the lever (1) towards the twistgrip to operate the front brake. The system is hydraulically assisted and you only need to pull the lever gently.

The brake lever has a wheel (2) for adjusting the distance between lever and twistgrip on the handlebar.

To make the adjustment, hold the lever (1) fully forward and adjust the wheel (2), turning it to one of the four preset positions.

Note that:

position n° 1 corresponds to the maximum distance between the lever and grip, while position n° 4 corresponds to the minimum distance.



### Warning

Any adjustment of clutch and brake levers must only be carried out when motorcycle is stationary.



### Warning

Before using these controls, read the instructions on page 36.

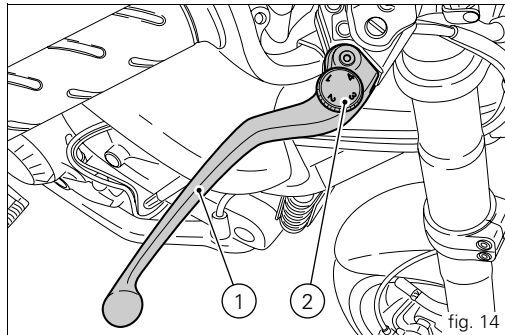

## Rear brake pedal (fig. 15)

Push down on the pedal (1) with your foot to operate the rear brake.

The system is controlled hydraulically.

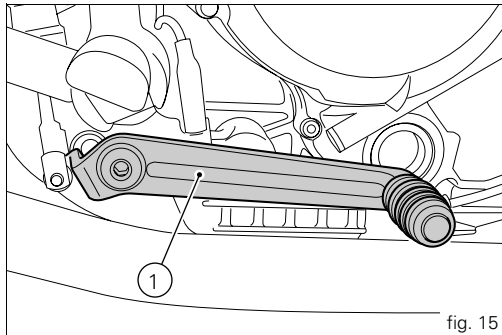

## Gearchange pedal (fig. 16)

The gearchange pedal has a central position N, with automatic return, and two directions of movement:

- down = push down on the pedal to engage 1<sup>st</sup> gear and to shift down. At this point the N warning light on the instrument panel will go off;
- up = lift the pedal to engage 2<sup>nd</sup> gear and then 3<sup>rd</sup>, 4<sup>th</sup>, 5<sup>th</sup> and 6<sup>th</sup> gears.

Each time you move the pedal you engage the next gear, one gear at a time.

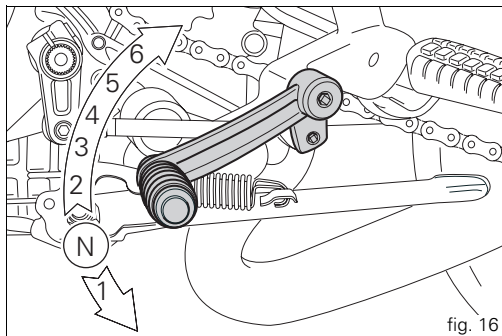

## Adjusting the position of the gearchange and rear brake pedals

The position of the gearchange and rear brake pedals in relation to the footrests can be adjusted to suit the requirements of the rider.

To adjust the position, proceed as follows.

Restrain the tie-rod (1) and slacken the locknuts (2) and (3).



### Notes

The locknut (2) has a left-hand thread.

Rotate the tie-rod (1) using an open-ended wrench on the flats (A) to move the gearchange pedal to the required position.

Tighten the two lock nuts onto the tie-rod.

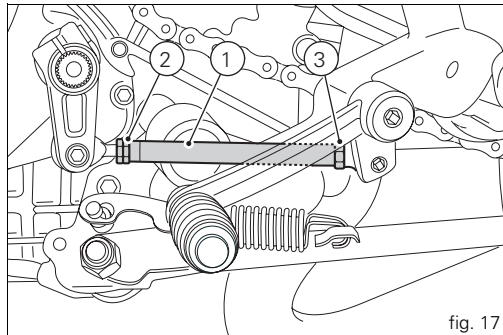

To adjust the position of the rear brake pedal, proceed as follows.

Loosen the locknut (4).

Turn the pedal travel adjustment bolt (5) until the pedal is in the desired position.

Tighten the locknut (4).

Operate the pedal by hand to make sure it has 1.5 to 2 mm of free play before the brake begins to bite.

If not, adjust the length of brake master cylinder pushrod as follows.

Slacken off the locknut (6) on the pushrod.

Screw the rod into the clevis (7) to increase play, or unscrew it to reduce play.

Tighten the locknut (6) and recheck the pedal freeplay.

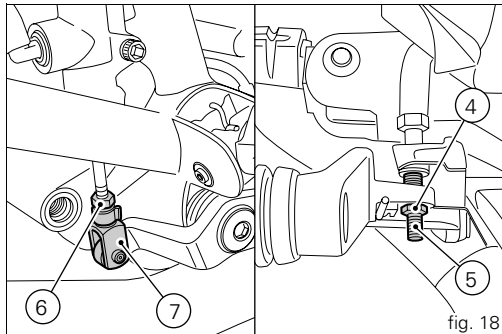

# Main components and devices

## Position on motorcycle (fig. 19)

- 1) Fuel tank filler cap.
- 2) Seat lock and helmet holder.
- 3) Sidestand.
- 4) Rearview mirrors.
- 5) Rear shock absorber adjusters.
- 6) Catalytic converter (except USA version).

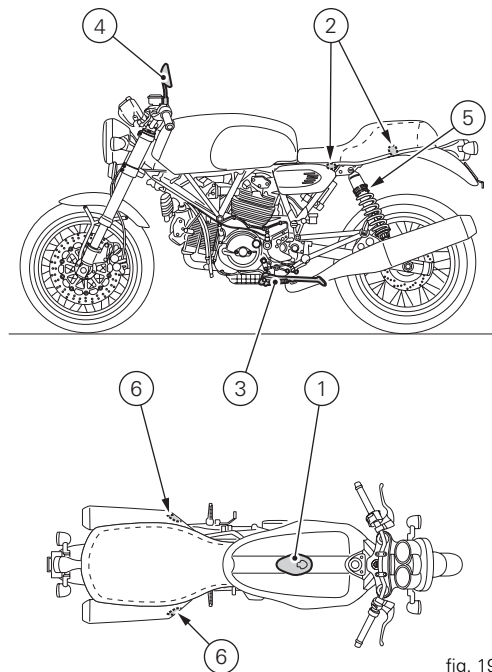

fig. 19

## Fuel tank filler cap (fig. 20 and fig. 21)

### Opening

Raise the cover (1) and insert the key into the lock.  
Give the key a 1/4 turn clockwise to unlock.  
Raise the cap (2).

### Closing

Close the cap with the key inserted and push it into its seat.  
Turn the key anticlockwise to the initial position and remove it.  
Replace the lock cover (1).



### Notes

The cap can only be closed with the key inserted.



### Warning

After each refuelling (see page 40) always make sure that the cap is correctly replaced and locked.

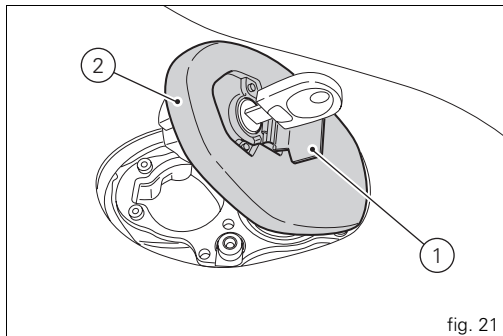
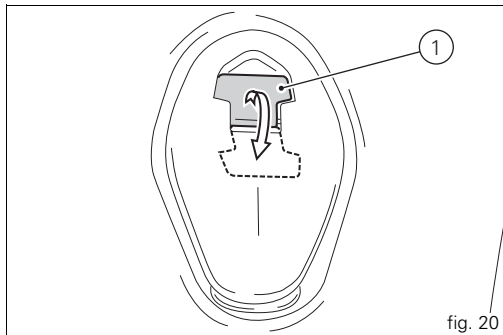

## Seat lock and helmet holder

### Opening (fig. 22)

Insert the key in the lock (1) and turn it clockwise to raise the rear of the seat. Withdraw the pins from the catches (2) on the frame.

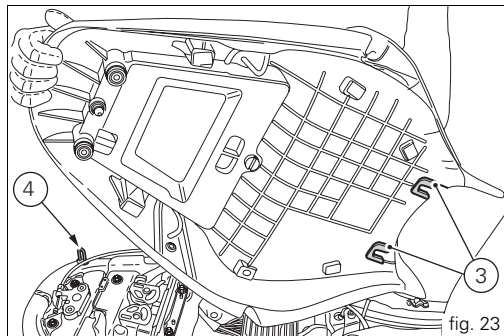
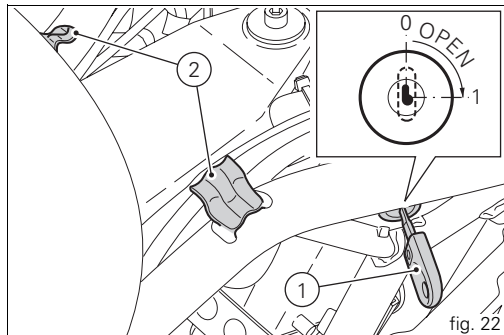

The helmet hook (4, fig. 23 - fig. 24) for attachment of the rider's and passenger's helmets is located on the rear of the frame under the seat. Pass the cable through the helmets and insert the end of the cable in the catch; leave the helmets hanging and replace the seat to secure them.



### Warning

This device protects the helmet against theft when the motorcycle is parked. Do not leave the helmet attached in this way when riding the motorcycle, as it can interfere with your movements and cause loss of control of the motorcycle.

### Closing

Make sure all parts are correctly arranged and secured in the underseat compartment. Insert the seat pins (3, fig. 23) in the catches (2, fig. 22) on the frame, then push the rear of the seat until you hear the bolt in the lock click into place. Check that the seat is firmly secured to the frame and remove the key from the lock (1, fig. 22).

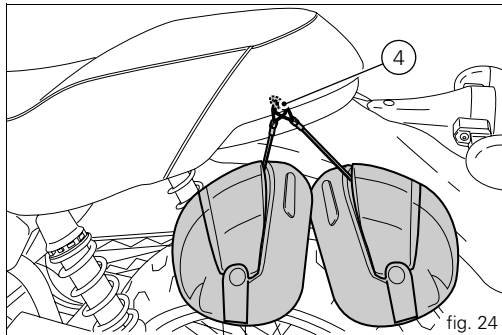



## Sidestand (fig. 25)

### Important

Before lowering the sidestand, check that the ground is sufficiently even and hard. Do not park on soft or pebbled ground or on asphalt melted by the sun etc. or the motorcycle may fall over.

When parking on a slope, always park with the rear wheel on the downhill side.

To lower the sidestand, hold the motorcycle handlebars with both hands and push down on the stand (1) with your foot until it is fully extended. Tilt the motorcycle until the sidestand is resting on the ground.

### Warning

Do not sit on the motorcycle when it is supported on the sidestand.

To raise the sidestand to rest position (horizontal position), tilt the motorcycle to the right and, at the same time, lift the stand (1) with your foot.

### Notes

It is advisable to check periodically that the stand mechanism (consisting of two springs, one inside the other) and safety sensor (2) are working properly.

### Notes

The engine can be started with the sidestand down and the gearbox in neutral. If starting with a gear engaged, pull in the clutch lever (in this case the sidestand must be up).

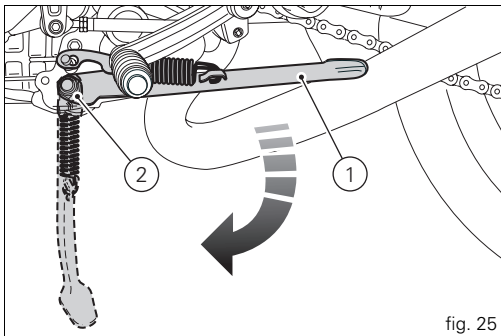

fig. 25

## Rear shock absorber adjusters (fig. 26)

The shock absorber has outer adjusters that enable you to adjust the motorcycle's rear suspension to suit the load.

The two nuts (1) on the upper part of the shock absorber serve to adjust the preload on the external spring.

To change the spring preload, turn the upper nut.

Then **SCREW IN** or **SCREW OUT** the lower nut to **INCREASE** or **DECREASE** spring preload as required.

The standard setting is the minimum preload position; from this position the preload can be increased through four positions; 1 click = 4 mm.

**STANDARD** length of the preloaded spring on the shock absorber:  $214 \pm 1.5$  mm.

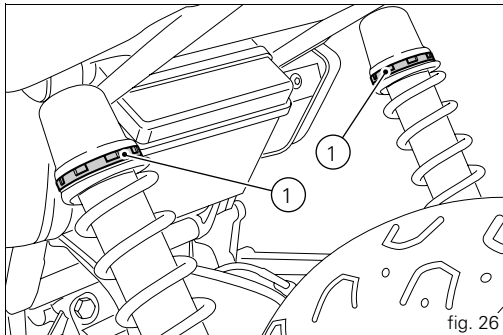

# Riding the motorcycle

## Running-in recommendations

### Max. rpm (fig. 27)

Rpm limits to be observed during the running-in period and in normal use:

- 1) up to 1000 km;
- 2) from 1000 to 2500 km.

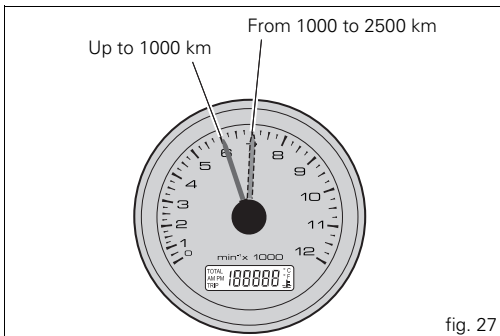

fig. 27

### Up to 1000 km

During the first 1000 km, keep an eye on the tachometer. The revs should never exceed 5500-6000 rpm.

During the first hours of riding, it is advisable to continuously vary the load on the engine and the rpm, though still keeping within the above limits.

For this reason, roads with numerous bends and hilly areas are ideal for running in the engine, brakes and suspension.

For the first 100 km use the brakes gently. Avoid sudden or prolonged braking. This will allow the friction material on the brake pads to bed in against the brake discs.

To allow all the mechanical moving parts in the motorcycle to adapt to one another, and to avoid shortening the life of the main engine components, it is advisable to avoid sudden acceleration and running the engine at high rpm for too long, especially uphill.

It is also advisable to check the drive chain frequently and ensure that it is lubricated as required.

### From 1000 to 2500 km

You can take more power from the engine, but you should never go above 7000 rpm.

## Important

Throughout the running-in period, be careful to stick to the recommended maintenance schedule and periodic service intervals indicated in the warranty booklet. Failure to follow these instructions will release Ducati Motor Holding S.p.A. from any liability for any engine damage or shortened engine life.

Keeping to the running-in recommendations will ensure longer engine life and reduce the need for overhauls and re-tuning.

## Pre-ride checks

### Warning

Failure to carry out these checks before starting may result in damage to the motorcycle and injury to rider.

Before starting, check the following points:

#### FUEL LEVEL IN THE TANK

Check the fuel level in the tank. Re-fuel if necessary (page 40).

#### ENGINE OIL LEVEL

Check the oil level in the sump through the sight glass. Top up if necessary (page 60).

#### BRAKE AND CLUTCH FLUID

Check the fluid levels in the respective reservoirs.

#### TYRE CONDITION

Check the pressure and condition of the tyres (page 58).

## CONTROLS

Operate the brake, clutch, gearchange and throttle controls (lever, pedal and twistgrip) and check that they function correctly.

## LIGHTS AND INDICATORS

Check that lights, indicators and horn are working properly. Replace any burnt-out bulbs (page 51).

## KEY LOCKS

Check that the fuel filler cap and the seat are locked.

## SIDESTAND

Make sure side stand operates smoothly and is in the correct position (page 32).

### Warning

If there are any faults or malfunctions, do not start the motorcycle and contact your DUCATI Dealer or Authorized Service Centre.

## Starting the engine



### Warning

Before starting the engine, familiarise yourself with the controls that you will use when riding (page 10).

- 1) Turn the ignition switch to ON (fig. 28). Check that both the green light N and the red light  on the instrument panel come on.



### Important

The oil pressure light should go out a few seconds after the engine has started (page 11).



### Notes

The engine can be started with the sidestand down and the gearbox in neutral. If starting with a gear engaged, pull in the clutch lever (in this case the sidestand must be up).

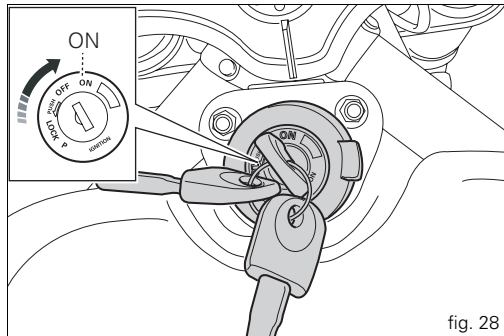



fig. 28

- 2) Make sure that the stop switch (1, fig. 29) is in the  RUN position, then press the starter button (2, fig. 29).

This model has servo-assisted starting.

To use the servo-assisted starting feature, press the start button (2) and release it immediately. When you press the button (2) the starter motor operates automatically for a maximum time determined by the engine temperature. The system disengages the starter motor as soon as the engine starts. If the engine fails to start, wait at least 2 seconds before pressing the start button (2) again. Allow the engine to start without turning the throttle twistgrip.

### Important

Do not rev the engine when cold. Allow some time for the oil to warm up and reach all points that need lubricating.

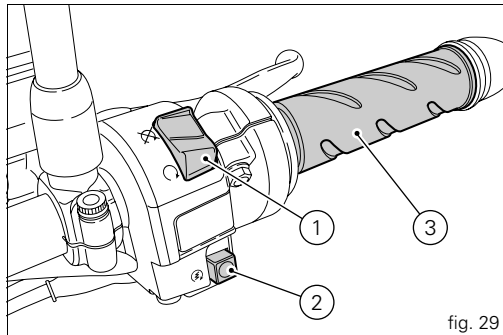

fig. 29

## Moving off

- 1) Disengage the clutch by squeezing the control lever.
- 2) Push down the gearchange lever firmly with the tip of your foot to engage first gear.
- 3) Raise the engine revs by turning the throttle twistgrip while gradually releasing the clutch lever. The motorcycle will start moving.
- 4) Release the clutch lever completely and accelerate.
- 5) To change to second gear, close the throttle to reduce the engine revs, disengage the clutch, lift the gearchange lever and release the clutch lever. To change down, proceed as follows: release the twistgrip, disengage the clutch, briefly rev the engine to allow the gears to synchronize, shift down and release the clutch. Use the controls intelligently and opportunely: when riding uphill, change down immediately when the motorcycle begins to slow down, to avoid abnormal strain on the motorcycle frame and the engine.



### Important

Avoid sudden acceleration, as this may lead to misfiring and transmission snatching. The clutch lever should not be held in longer than necessary after a gear is engaged, otherwise friction parts may overheat and wear out.

## Braking

Slow down in time, change down to use the engine brake, then apply both brakes. Pull in the clutch lever before the motorcycle comes to a stop to prevent the engine stalling.



### Warning

Use both the brake lever and the brake pedal for effective braking. Using only one of the brakes will give you less braking power.

Never use the brake controls harshly or suddenly as you may lock the wheels and lose control of the motorcycle. When riding in the rain or on slippery surfaces, braking capacity is significantly reduced. Always use the brakes very gently and carefully when riding under these conditions. Any sudden manoeuvres may lead to loss of control. When riding down long, steep downhill slopes, change down to use engine braking. Apply the brakes intermittently for brief periods only. Keeping the brakes applied continuously causes the friction material to overheat and dangerously reduces braking effectiveness. Under-inflated tyres reduce braking efficiency and may adversely affect handling and road-holding on bends.

## Stopping the motorcycle

Reduce speed, change down and release the throttle twistgrip. Change down to engage first gear and then neutral. Apply the brakes and bring the motorcycle to a complete stop. Switch the engine off by turning the key to OFF (page 20).

### Important

Do not leave the key in the ON position when the engine is stopped as this could damage electrical components.

## Parking

Stop and park the motorcycle on the side stand (see page 32).

To prevent theft, turn the handlebar fully left and turn the ignition key to the LOCK position.

If you park in a garage or other indoor area, make sure that there is proper ventilation and that the motorcycle is not near a source of heat.

If necessary, you can leave the side lights on by turning the key to position P.

### Important

Do not leave the key at P for long periods or the battery will run down. Never leave the motorcycle unattended with the ignition key inserted.



## Warning

The exhaust system may still be hot even after engine is switched off; so take special care not to touch it with any part of the body and do not park the motorcycle next to inflammable material (wood, leaves, etc.).



## Warning

Using padlocks or other locks designed to prevent movement of the motorcycle (such as brake disc locks, rear sprocket locks, and so on) is very dangerous, and may impair motorcycle operation and the safety of rider and passenger.



## Refuelling

Do not overfill the tank when refuelling. The fuel level should remain below the rim of the filler cap recess (fig. 30).



## Warning

Use fuel with low lead content and an original octane number of at least 95. Check that no fuel is trapped in the filler cap recess.

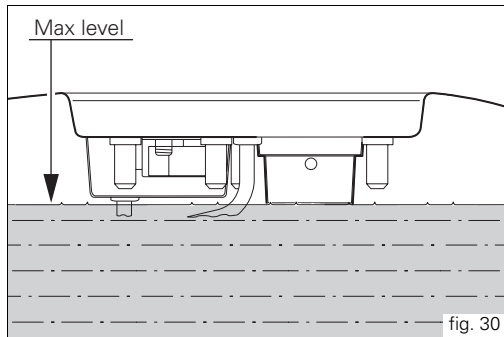

## Toolkit and accessories (fig. 31)

In the underseat compartment there is a bag (1) which contains:

- use and maintenance manual;
- helmet fastening cable;
- toolkit for routine maintenance operations and checks.

To access the underseat compartment, open the lock and remove the seat (page 30), unscrew the screw (2) and lift the cover (3).

## Toolkit (fig. 32)

Contains:

- spark plug wrench (4);
- tommy bar for spark plug wrench (5);
- double-ended screwdriver (6);
- helmet fastening cable (7).

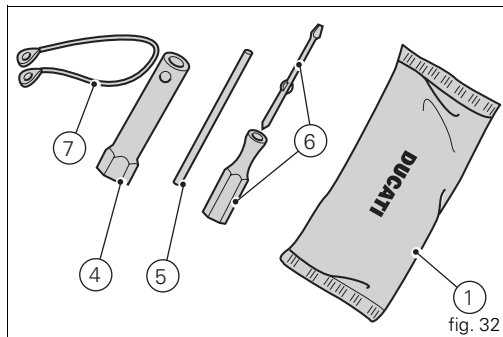
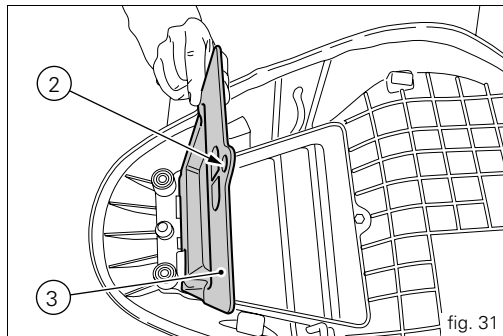

# Main Maintenance Operations

## Checking the brake and clutch fluid level

The levels should not fall below the MIN. marks on the respective reservoirs (fig. 33 and fig. 34).

If the level is too low it can allow air to get into the circuit, thus impairing the efficiency of the relative system.

To top up or change the brake and clutch fluid at the intervals specified in the periodic maintenance table (see Warranty Booklet), contact your Ducati Dealer or Authorized Service Centre.

## Important

It is recommended that all brake and clutch hoses be renewed every four years.

## Brake system

If there is excessive play at the brake lever or pedal even though the brake pads are still in good condition, contact a Ducati Dealer or Authorized Service Centre to have the system inspected and any air expelled from the circuit.



## Warning

Brake and clutch fluid is harmful to paintwork and plastic parts, so do not allow it to come into contact with them. Hydraulic oil is corrosive and can cause damage and injuries.

Never mix different quality oils.

Check that the seals are in good condition.

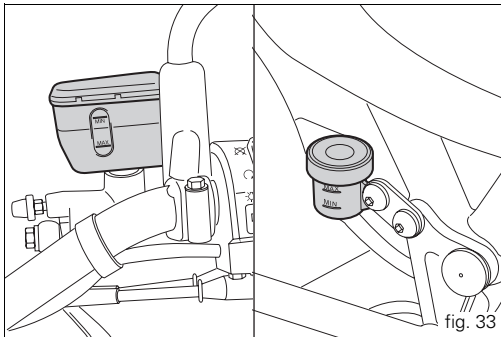

## Clutch system

If there is too much play at the control lever and the motorcycle jumps or stops when a gear is engaged, this indicates air in the system. Contact a Ducati Dealer or Authorized Service Centre to have the system inspected and the air bled from the system.

**Warning** The level of clutch fluid tends to increase in the reservoir as the friction material on the clutch plates wears out. Do not exceed the specified level (3 mm above minimum level).

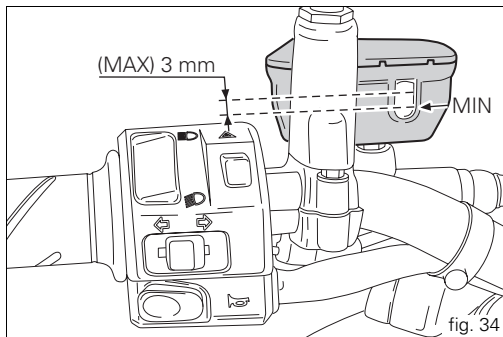

## Checking the brake pads for wear (fig. 35)

### Front brake

The brake pads are marked with wear indicators so that they can be checked without removing them from the calipers. If the grooves in the pad friction material are still visible, the pad is still in good condition.

### Rear brake

The thickness of the friction material on each pad must be at least 1 mm.

### Important

Have the brake pads replaced at a Ducati Dealer or Authorized Service Centre.

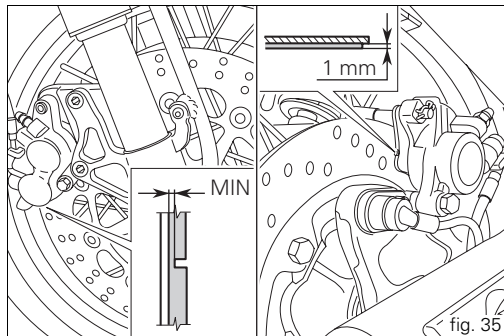

## Lubricating cables and joints

The condition of the outer throttle cables should be checked at regular intervals. The sheath should show no signs of kinking or cracking. Operate the control to check that the inner cable slides smoothly inside the outer cable: if you feel any rubbing or catching, have the cable replaced by a Ducati Dealer or Authorized Service Centre.

To prevent problems, periodically lubricate the ends of each control cable with SHELL Advance Grease or Retinax LX2.

To prevent problems, periodically open the twistgrip housing by unscrewing the two screws (1, fig. 36) and lubricate the ends of each control cable and the races with SHELL Advance Grease or Retinax LX2.

### Warning

Close the twistgrip housing carefully, inserting the cable in the race.

Refit the cover and tighten the screws (1) to 6 Nm.

To ensure smooth operation of the pivot on the sidestand, remove any dirt and apply SHELL Alvania R3 to all points subject to friction (fig. 37).

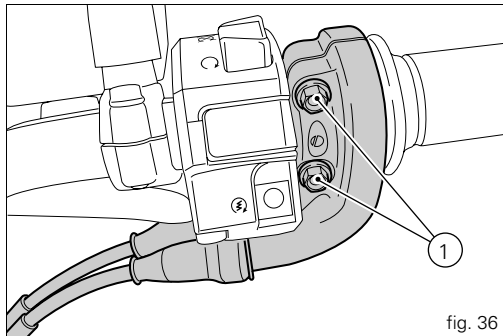

fig. 36

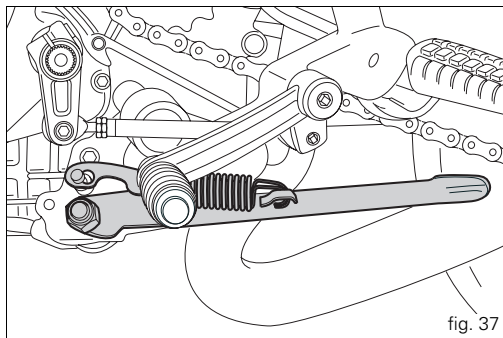

fig. 37

**E**

## Adjusting the throttle cable

In all handlebar positions, the throttle twistgrip should have free play of 1.5 to 2 mm measured in terms of rotation of the outer circumference of the twistgrip. If this is not the case, adjust the cable by means of the adjusters (1) on the throttle body (fig. 39).

### Important

To adjust the free play of the throttle twistgrip, contact your Ducati dealer or Authorised Service Centre.

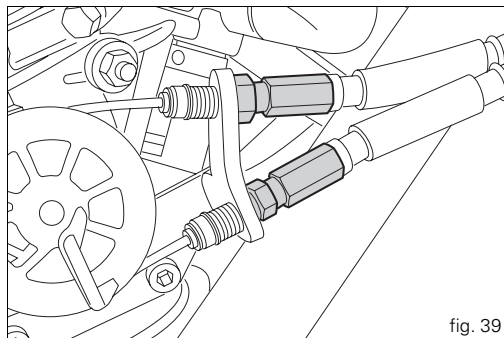
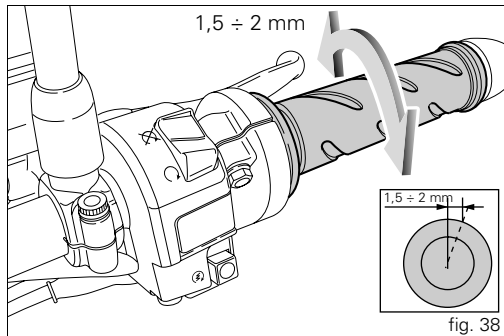

## Charging the battery (fig. 40)

Before charging the battery, it is best to remove it from the motorcycle.

Unscrew the screws (1) securing the battery mounting tray to the frame.

Remove the cover (2), releasing the elastic strap from the two side clips.

First disconnect the black negative terminal (-), then the red positive terminal (+).

Slide the battery towards the rear of the motorcycle in order to remove it from the mounting tray.

### Warning

The battery produces explosive gases: keep it away from heat sources and flames.

Charge the battery in a well-ventilated area.

Connect the battery charger leads to the battery terminals: red to the positive terminal (+), black to the negative terminal (-).

### Important

Connect the battery to the charger before switching on the charger to prevent sparks at the battery terminals that could ignite the gases inside the cells. Always connect the red positive terminal first.

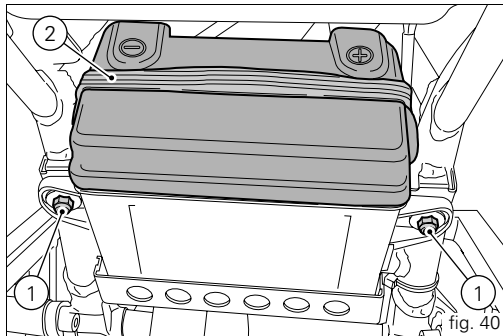





## Warning

Keep the battery out of the reach of children.

Charge the battery at 1 A for 5-10 hours.

Replace the battery in the mounting tray (2, fig. 40), and fix the mounting tray to the frame by tightening the screws (1, fig. 40) to a torque of 10 Nm.

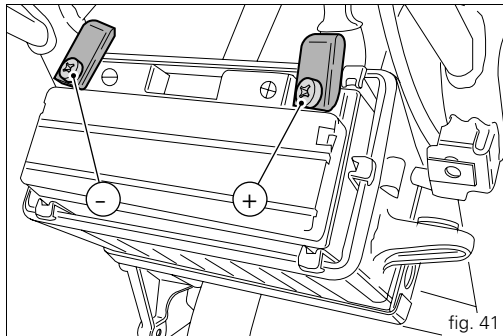

## Tensioning the drive chain

Turn the rear wheel slowly until you find the position in which the chain is most taut.

With the motorcycle resting on its sidestand, push the chain with your finger in correspondence with the mid point of the swingarm. The lower run of the chain should deflect by approximately 27 to 29 mm.

To adjust the tension, loosen the axle nut (1, fig. 43) and screw in the adjuster screws (2) on both sides of the swingarm by the same amount to tighten the chain or unscrew them to slacken it. In the latter case, you will need to push the wheel forward.

### Important

An incorrectly tensioned chain will lead to accelerated wear of the transmission components.

Check that the notches in the sliders (3, fig. 43) on both sides of the swingarm are lined up with the same positioning marks (A) to ensure that the wheel is aligned correctly. Grease the thread of the axle nut (1) with SHELL Retinax HDX2 and tighten to a torque of 72 Nm. Grease the threads of the adjuster nutss (2) with SHELL Alvania R3 and tighten to a torque of 8 Nm.

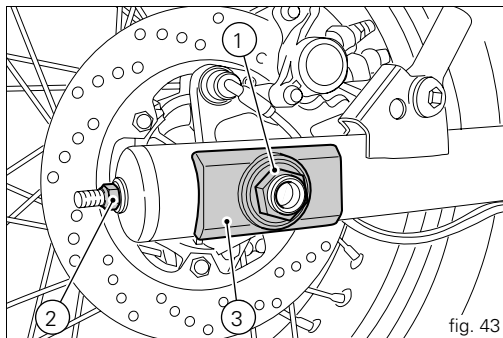
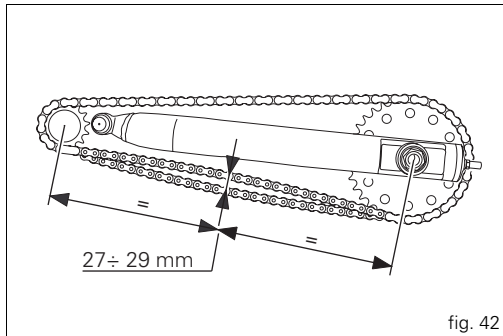

**E**

## Lubricating the drive chain

The chain fitted on your motorcycle has O-rings to protect its moving parts from dirt, and to hold the lubricant inside. So as not to damage these seals when cleaning the chain, use special solvents and avoid aggressive washing with high-pressure steam cleaners. After cleaning, blow the chain dry with compressed air or wipe with an absorbent material, then lubricate each link with SHELL Advance Chain or Advance Teflon Chain.



### Important

Using non-specific lubricants may cause severe damage to the chain and the front and rear sprockets.

## Changing light bulbs

Before replacing a burnt-out bulb, check that the new one complies with voltage and wattage specified in the “Electrical System” paragraph on page 76. Always check that the new bulb works before refitting all the parts.

### Headlight

To access the headlight bulbs, loosen the lower screw (1) that attaches the lens/reflector assembly to the shell. Disconnect the wiring connector (2, fig. 45) from the headlight bulb. Release the bulb retaining clip (3, fig. 45) and remove the bulb from its housing.



### Notes

Be careful to hold the new bulb at the base only. Never touch the transparent body with your fingers or it will blacken resulting in reduced bulb brilliancy.

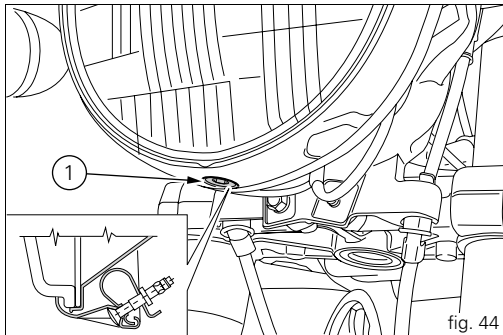

fig. 44

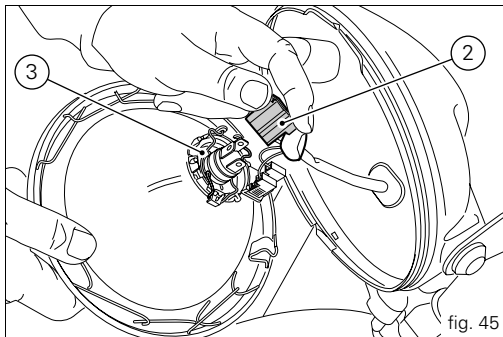

fig. 45

Change the bulbs (4).

E



### Notes

Do not touch the transparent part of the bulb with your fingers as this will darken it and cause a loss of brightness. Insert the tabs on the bulb base into the corresponding slots in the bulb housing to ensure the bulb is correctly positioned; hook the end of the clip (3, fig. 45) on to the headlight mountings. Reconnect the wiring.

To renew the side light bulb, detach the wiring connector. The bulb (5) is of the bayonet-type: press and twist counter-clockwise to remove. Push the new bulb in and turn it clockwise until it clicks into place. Reconnect the wiring connector and replace the lens/reflector assembly.

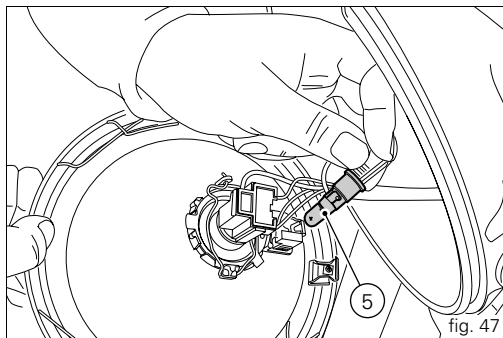
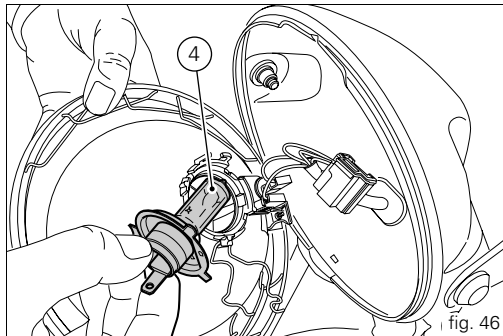

## Front turn signals (fig. 48)

Loosen the screw (1) and detach the lens (2) from the turn signal light.

The bulb has a bayonet-type base: to remove it, push it in and turn it counter-clockwise. Push in the new bulb and turn it clockwise until it clicks into place. Refit the lens (2). Refit and tighten the screw (1).

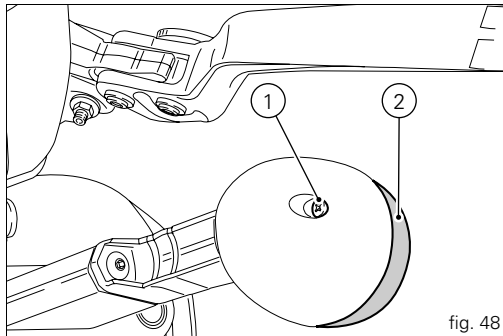

## Rear turn signals (fig. 49 and fig. 50)

Loosen the screw (1) and detach the lens (2) from the turn signal light. Withdraw the bulb assembly (4) from the bulb holder (5).

Change the bulb and insert the bulb assembly (4) in the bulb support (5). Refit the lens (2) with the bulb holder (5) to the turn signal (3), inserting the two pins on the bulb holder (5) in the corresponding locations in the turn signal (3). Refit and tighten the screw (1).

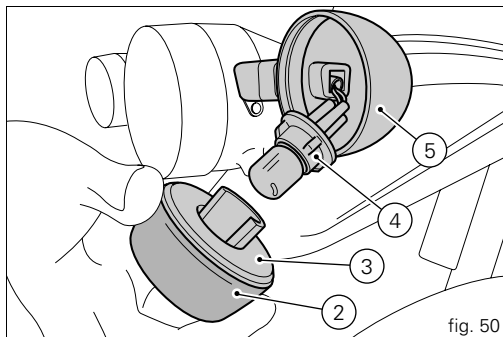
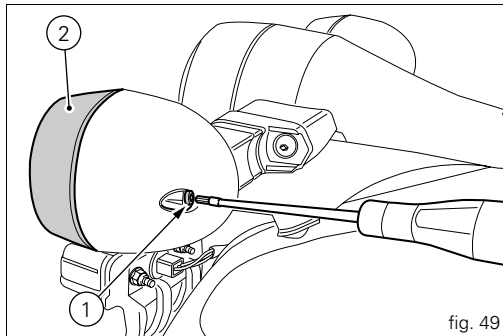

## Number plate light (fig. 51)

To access the bulb of the number plate light, withdraw the bulbe holder from inside the number plate holder. Extract the bulb and renew.



### Notes

To avoid pulling on the wires, hold the bulb holder by point (A, fig. 51) when pulling it out of the number plate holder.

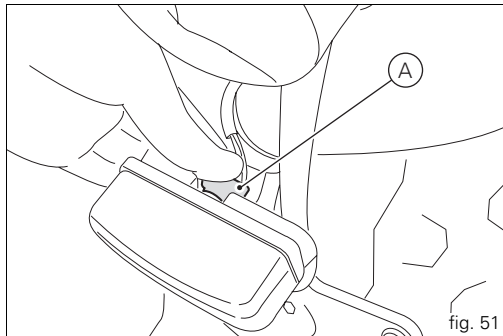



## Brake light

To change the brake light bulb, loosen the two screws (1, fig. 52) securing the lens and remove it. The bulb has a bayonet-type base: to remove it, push it in and turn it counter-clockwise. Push in the new bulb and turn it clockwise until it clicks into place (fig. 53). Refit the lens and tighten screws (1).

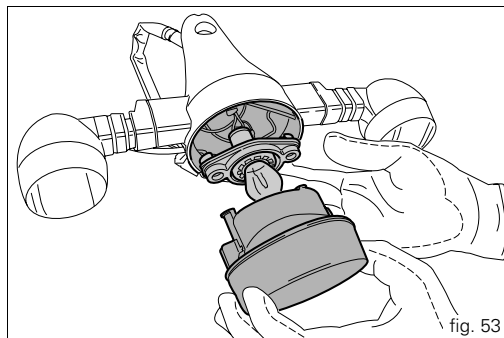
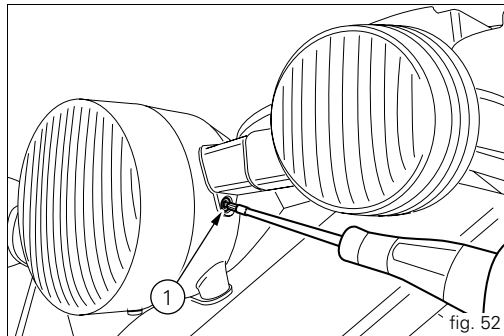

## Headlight aim (fig. 54)

To check the headlight aim, place the motorcycle upright with the tyres inflated to the correct pressure and one person sitting astride the motorcycle. The motorcycle should be perfectly vertical, with its longitudinal axis at right angles to a wall or screen at a distance of 10 metres. Draw a horizontal line on the wall at the height of the centre of the headlight and a vertical one in line with the longitudinal axis of the motorcycle.

If possible, perform this check in conditions of low ambient light.

Switch on the low beam headlight.

The height of the upper limit between the dark area and the lit area must not be more than nine tenths of the height of the centre of the headlamp from the ground.

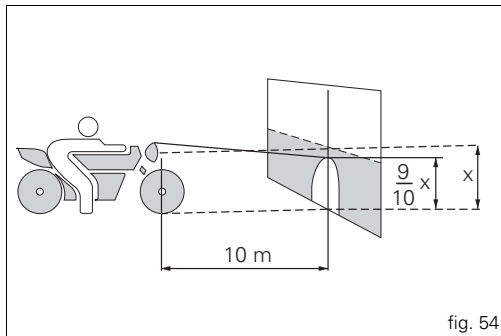



fig. 54

## Notes

 Note: this procedure is the one specified by Italian regulations for checking the maximum height of light beams. Owners in other countries should adapt this procedure to the regulations in force in the country where the motorcycle is used.

The vertical aim of the headlamp is adjusted by turning the screws (1, fig. 55) that attach it to the side mountings.

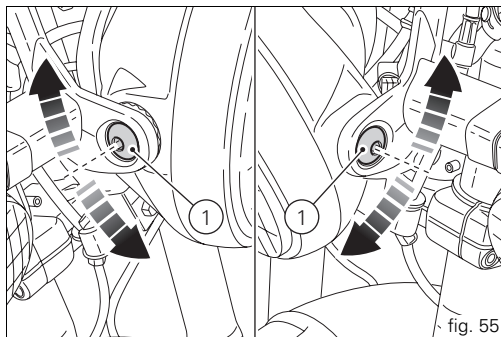

fig. 55

## Tyres

Front tyre pressure:

2.2 bar.

Rear tyre pressure:

2.2 bar.

As tyre pressures are affected by changes in temperature and altitude, check and adjust them whenever you are riding in areas where there are large variations in temperature or altitude.



### Important

Check and adjust the pressures with the tyres cold.

To prevent distortion of the front wheel rim, increase tyre pressure by 0.2 - 0.3 bar when riding on bumpy roads.

## Repairing or renewing tyres

With minor punctures, tyres with inner tubes deflate relatively quickly. If you find that one of the tyres is slightly deflated, check the tyre for slow punctures.



### Warning

In case of a puncture, change both the tyre and inner tube. Replace with tyres and inner tubes of the original brand and type. Be sure to tighten the valve dust caps securely to prevent leaks while riding. Never fit tubeless tyres, as this could cause a sudden loss of pressure in the tyre, with possibly serious consequences for the rider and passenger. After renewing a tyre and inner tube, the wheel must be balanced.



### Important

Do not remove or alter the position of the wheel balancing weights.



### Notes

If tyres and inner tubes need changing, contact a Ducati Dealer or Authorized Service Centre to make sure wheels are removed and refitted correctly.

## Minimum tread depth

Measure the tread depth (S, fig. 56) at the point where the tread is most worn.

It should not be less than 2 mm, and in any case not less than the legal limit.



### Important

Visually inspect the tyres at regular intervals for cracks and cuts, especially on the side walls, and bulges or large stains that indicate internal damage. Replace them if badly damaged.

Remove any stones or other foreign bodies stuck in the tread.

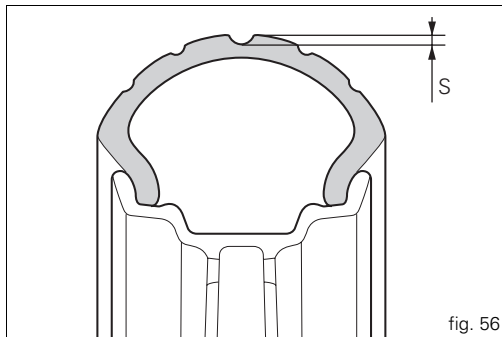

## Checking the engine oil level (fig. 57)

The engine oil level can be checked through the sight glass (1) provided on the clutch cover.

Check the oil level with the motorcycle upright and the engine cold. Allow a few minutes for the oil level to stabilize after stopping the engine. The oil level should be between the two marks next to the sight glass.

If the level is low, top up with SHELL Advance Ultra 4 engine oil.

Remove the oil filler cap (2) and top up until the oil reaches the required level. Replace the filler cap.

## Important

To change the engine oil and oil filters at the intervals specified in the routine maintenance schedule (see Warranty Card), contact your Ducati Dealer or Authorized Workshop.

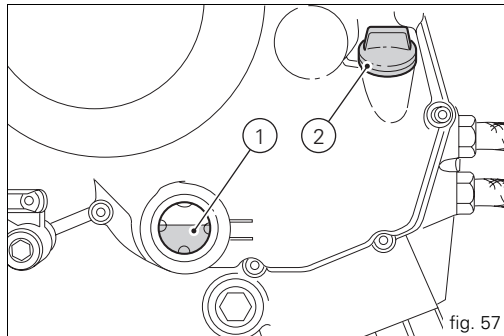

## Oil viscosity

SAE 15W-50

The other viscosity values shown in the table can be used if the local average temperature is within the limits specified for that oil viscosity.

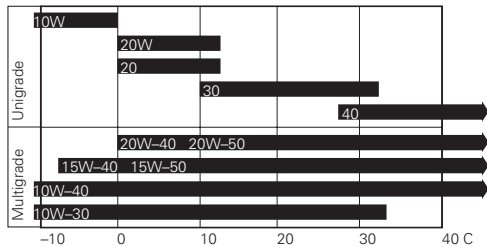

## Cleaning and renewing the spark plugs (fig. 58)

Spark plugs are an important part of the engine and should be checked at regular intervals.

This is a relatively simple operation and provides a good indication of how well the engine is running.

Pull the spark plug caps off the spark plugs and remove the plugs from the cylinder heads using the wrench supplied in the toolkit.

Check the colour of the ceramic insulation around the central electrode: an even brown colour is a sign that the engine is in good condition.

If the insulation is any other colour, or if there are dark deposits, renew the spark plug and describe the condition of the old plug to a Ducati dealer or Authorized Service Centre. Also check the central electrode; if it is worn or glazed, renew the spark plug.

Check the electrode gap, which must be 0.6 to 0.7 mm.

### Important

Take care when bending the side electrode to adjust the gap. A gap outside the specified limits will adversely affect engine performance and may lead to difficult starting or erratic idling.

Thoroughly clean the electrode and insulation using a wire brush, and check the condition of the washer.

Clean the spark plug seat in the cylinder head, and take care not to allow foreign objects to fall inside the combustion chamber.

Refit the spark plug in the cylinder head, screwing it fully into the bore. Tighten to 20 Nm.

If you do not have a torque wrench, tighten the plug by hand, then give it a further 1/2 turn with the spark plug wrench supplied in the toolkit.

### Important

Do not use spark plugs with inadequate thermal rating or incorrect thread length.

The spark plug must be tightened correctly.

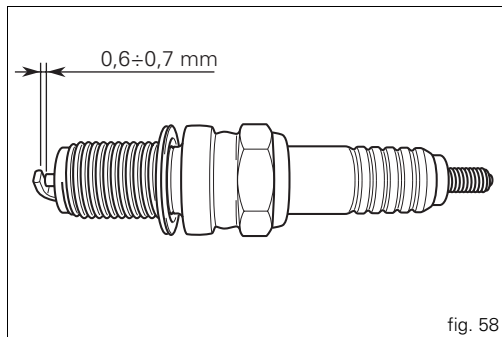

fig. 58

## General cleaning

To preserve the original shine on metal surfaces and paintwork, wash and clean your motorcycle at regular intervals depending on the type of use and according to the particular road conditions. Use specific products, where possible biodegradable. Avoid aggressive detergents or solvents.



### Important

Do not wash your motorcycle immediately after use, as marks can form due to evaporation of the water on hot surfaces.

Never clean the motorcycle using hot or high-pressure water jets. The use of high-pressure washers may cause the seizure and other problems with the forks and fork seals, wheel hubs, electrical system, air intakes and exhaust silencers, and consequently impair the safety of the motorcycle.

If parts of the engine are especially dirty or greasy, use a degreasing agent, avoiding contact with transmission components (chain, front and rear sprockets, etc.). Rinse with warm water and dry all surfaces with chamois leather.



### Warning

There may be loss of braking efficiency immediately after washing the motorcycle.

Never grease or lubricate the brake discs. This will cause loss of braking efficiency.  
Clean the discs with an oil-free solvent.



### Warning

When cleaning the seat, avoid rubbing it too hard and the use of alcohol or other types of solvent; only use water to clean the rear of the seat with the logo. The use of cleaning agents other than water could cause discoloration or removal of the paint.

## Storing the motorcycle

If the motorcycle is to be left unused for a long period, it is advisable to carry out the following operations first:

- clean the motorcycle;
- drain the fuel from fuel tank;
- pour a few drops of engine oil into the cylinders through the spark plug bores, then crank the engine by hand a few times to form a protective film of oil on the cylinder inner walls;
- place the motorcycle on the paddock stand;
- disconnect and remove the battery. If the motorcycle has been left unused for more than a month, the battery should be checked and re-charged if necessary.

Protect the motorcycle with a special motorcycle cover that will not damage the paintwork or retain moisture.

This type of motorcycle cover is available from Ducati Performance.

## Important notes

The legislation in some countries (France, Germany, Great Britain, Switzerland, etc.) sets certain noise and pollution standards.

Periodically carry out the required checks and renew parts as necessary, using Ducati original spare parts, in compliance with the regulations in the country concerned.



Programmed maintenance plan: operations to be carried out by the dealer

List of operations and frequency (distance or time interval*)	km x1000	1	12	24	36	48	60
	mi. x1000	0.6	7.5	15	22.5	30	37.5
	Months	6	12	24	36	48	60
Change the engine oil		●	●	●	●	●	●
Change the engine oil filter		●	●	●	●	●	●
Clean the engine oil pick-up filter					●		
Check the engine oil pressure				●		●	
Check and/or adjust the valve clearances (1)			●	●	●	●	●
Check the tension of the timing belts (1)			●		●		●
Renew the timing belts				●		●	
Check and clean the spark plugs. Renew if necessary				●		●	
Check and clean the air filter (1)			●		●		●

List of operations and frequency (distance or time interval*)	km x1000	1	12	24	36	48	60
	mi. x1000	0.6	7.5	15	22.5	30	37.5
	Months	6	12	24	36	48	60
Change the air filter				●		●	
Check throttle body synchronisation and idle speed setting (1)			●	●	●	●	●
Check the brake and clutch fluid levels		●	●	●	●	●	●
Change the clutch and brake fluid					●		
Check and adjust the brake and clutch control cables			●	●	●	●	●
Check/lubricate the throttle/cold start cable			●	●	●	●	●
Check tyre pressure and wear		●	●	●	●	●	●
Check the brake pads. Renew if necessary		●	●	●	●	●	●
Check the steering head bearings				●		●	
Check the drive chain tension, alignment and lubrication		●	●	●	●	●	●
Check the clutch disc pack. Renew if necessary (1)			●	●	●	●	●
Check the rear wheel cush drive				●		●	
Check the wheel hub bearings				●		●	
Check the indicators and lighting			●	●	●	●	●
Check tightness of nuts and bolts securing the engine to the frame			●	●	●	●	●
Check the sidestand			●	●	●	●	●
Check tightness of the front wheel axle nut			●	●	●	●	●
Check tightness of the rear wheel axle nut			●	●	●	●	●
Check the external fuel hoses			●	●	●	●	●

List of operations and frequency (distance or time interval*)	km x1000	1	12	24	36	48	60
	mi. x1000	0.6	7.5	15	22.5	30	37.5
	Months	6	12	24	36	48	60
Change the front fork oil					●		
Check the forks and rear shock absorber for oil leaks			●	●	●	●	●
Check the front sprocket retaining bolts			●	●	●	●	●
General lubrication and greasing			●	●	●	●	●
Check and recharge the battery			●	●	●	●	●
Road test the motorcycle		●	●	●	●	●	●
General cleaning			●	●	●	●	●
Check the wheels and spokes as indicated in the workshop manual (1)			●	●	●	●	●

\* Service operation to be carried out in accordance with the specified distance or time intervals (km, mi. or months), whichever occurs first.

(1) Operation to be carried out only at the specified distance intervals.

## Programmed maintenance plan: operations to be carried out by the customer

E

List of operations with type of intervention (distance or time interval*)	km x1000	1
	mi. x1000	0.6
	Months	6
Check the engine oil level		●
Check the brake and clutch fluid levels		●
Check tyre pressure and wear		●
Check the drive chain tension and lubrication		●
Check the brake pads. If necessary, contact your dealer to renew pads		●

\* Service operation to be carried out in accordance with the specified distance or time intervals (km, mi. or months), whichever occurs first.

### Dimensions GT 1000 (mm) (fig. 59)

#### Weights

Dry weight:

185 kg, without liquids and battery.

Fully laden:

390 kg.



#### Warning

Failure to observe weight limits could result in poor handling and impair the performance of your motorcycle, and could result in loss of control.

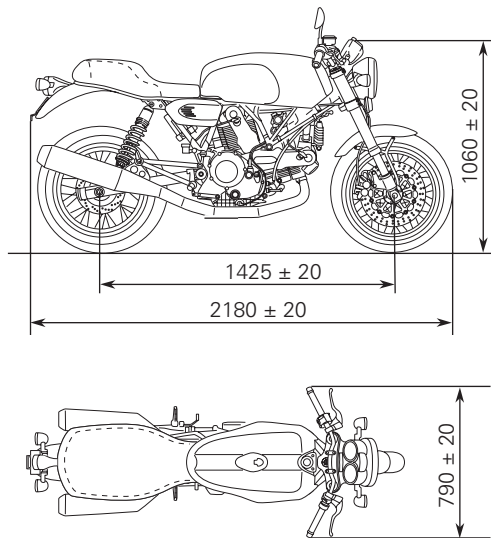

fig. 59

## Dimensions GT 1000 Touring (mm) (fig. 60)

### Weights

Dry weight:

185 kg, without liquids and battery.

Fully laden:

390 kg.



### Warning

Failure to observe weight limits could result in poor handling and impair the performance of your motorcycle, and could result in loss of control.

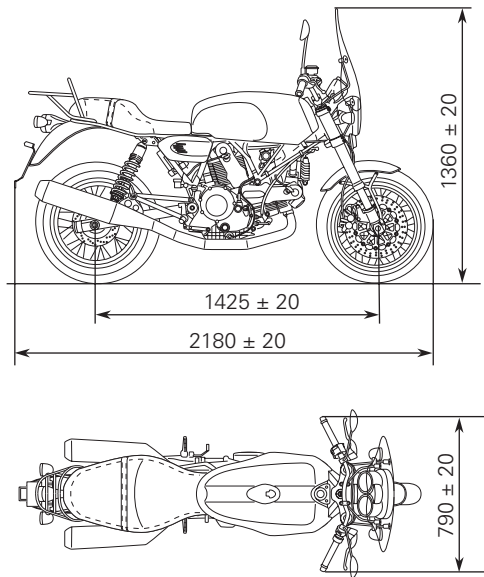

fig. 60

FUEL AND LUBRICANTS	TYPE	DM <sup>3</sup> (LITRES)
Fuel tank, including reserve of 3.5 dm <sup>3</sup> (litres)	Unleaded fuel with at least 95 octane rating	15
Sump and filter	SHELL - Advance Ultra 4	3.7
Front/rear brake and clutch circuits	Special hydraulic system fluid SHELL - Advance Brake Dot 4	—
Protection for electrical contacts	SHELL - Advance Contact Cleaner spray for electric systems	—
Front fork	SHELL - Advance Fork 7.5 or Donax TA	(each leg) 395 cm <sup>3</sup>



### Important

Do not use additives in fuel or lubricants.

## Engine

Longitudinal 90° "L" twin cylinder, four-stroke.

Bore (mm):

94.

Stroke (mm):

71.5.

Total displacement cm<sup>3</sup>:

992.

Compression ratio 1:10.0±0.5.

Max power at crankshaft (95/1/EC):

61 KW - 83 CV at 8,000 rpm.

Max torque at crankshaft (95/1/EC):

83 Nm - 8.5 kgm at 6,000 rpm.

## Important

Do not exceed the specified rpm limits in any running conditions.

## Timing system

DESMODROMIC with two valves per cylinder, operated by four rocker arms (two opening rockers and two closing rockers) and one overhead camshaft. Driven by the crankshaft through spur gears, timing belt pulleys and toothed timing belts.

## Desmodromic timing system (fig. 61)

- 1) Opening (or upper) rocker arm.
- 2) Opening shim.
- 3) Half rings.
- 4) Closing (or lower) shim.
- 5) Return spring for closing rocker.
- 6) Closing (or lower) rocker arm.
- 7) Camshaft.
- 8) Valve.

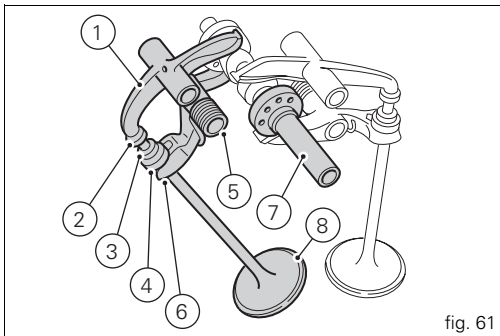



## Performance data

Maximum speed in any gear should be reached only after the correct running-in period with the motorcycle properly serviced at the recommended intervals.

## Brakes

### Front

Twin drilled discs.

Flange material:  
steel.

Braking surface material:  
stainless steel.

Disc diameter:  
320 mm.

Hydraulically operated by a control lever on right handlebar.

Braking surface:  
88 cm<sup>2</sup>.

Differential bore brake calipers.

Make:

BREMBO.

Type:

30/32a pistons.

Friction material:

Toshiba TT 2172 HH.

Master cylinder type:

PSC 16/25.

### Rear

With fixed drilled steel disc.

Braking surface material:  
stainless steel.

Disc diameter:  
245 mm.

Hydraulically operated by pedal on R.H. side.

Braking surface:  
25 cm<sup>2</sup>.

Make:

BREMBO.

Type:

P 34.

Friction material:

Toshiba TT 2172 HH.

Master cylinder type:

PS 11.



## Warning

The brake fluid used in the brake system is corrosive. In the event of accidental contact with eyes or skin, wash the affected area with copious amounts of running water.

## Transmission

Wet clutch: operated by control lever on left handlebar.  
Transmission from engine to gearbox main shaft via spur gears.  
Ratio:  
33/61.  
Gearbox:  
6 speed;  
with constant mesh gears, gearchange pedal on left.  
Front sprocket/clutch sprocket ratio:  
15/39.

Total gear ratios:

1<sup>st</sup> 15/37  
2<sup>nd</sup> 17/30  
3<sup>rd</sup> 20/27  
4<sup>th</sup> 22/24  
5<sup>th</sup> 24/23  
6<sup>th</sup> 28/24

Drive transmitted from gearbox to rear wheel via chain:

Make:  
RK  
Type:  
525 GXW  
Dimensions:  
5/8"x5/16".  
No. of links:  
100.



### Important

The above gear ratios are approved and should not be modified under any circumstances.

However, if you wish to tune up your motorcycle for competitions or special tracks, Ducati Motor Holding S.p.A. will be pleased to provide information about the special ratios available. Please contact a Ducati Dealer or Authorized Service Centre.



### Warning

To replace the rear sprocket, contact a Ducati Dealer or Authorized Service Centre. Incorrect replacement of this component could seriously endanger rider and passenger safety and cause irreparable damage to the motorcycle.

## Frame

High-strength tubular steel trellis with upper cage.

Steering angle (on each side):

28°.

Steering head rake:

24°.

Trail:

92 mm.

## Wheels

Spoked wheels.

### Front

Dimensions:

3.50x17".

### Rear

Make:

BREMBO

Dimensions:

5.50x17".

The front wheel has a removable axle.

## Tyres

### Front

Radial with inner tube

Size:

120/70-R17.

### Rear

Radial with inner tube.

Size:

180/55-R17.

## Spark plugs

Make:

CHAMPION.

Type:

RA 6 HC.

alternative

Make:

NGK.

Type:

DCPR8E.

## Fuel system

Indirect electronic injection (MARELLI CPU 5AM2)

Throttle body diameter: 45 mm.

Injectors per cylinder: 1.

Holes per injector: 1.

Fuel supply: 95-98 RON.

## Suspension

### Front

Lightweight upside-down hydraulic forks.

Leg diameter:

43 mm.

Travel along leg axis:

120 mm.

### Rear

The shock absorbers, which have the facility for spring preload adjustment, are pivot mounted at the lower end to a steel swingarm and to the frames. This system gives the motorcycle excellent stability.

Shock absorber travel:

94.5 mm.

Wheel travel:

133 mm.

## Exhaust system

Equipped with catalytic converter in compliance with Euro 3 emission regulations.

## Available colours

### GT 1000

Ducati anniversary red, code. 473.101 (PPG);

Transparent, 228.880 (PPG);

Black frame, chromed wheels

Ducati gloss black 248.514 (PPG) with white stripe;

Transparent, 228.880 (PPG);

Black frame, chromed wheels.

### GT 1000 Touring

Ducati gloss black 248.514 (PPG) with white stripe;

Transparent, 228.880 (PPG);

Black frame and wheels.

## Electrical system

The main components of the electrical system are:

### HEADLIGHT:

bulb type: H4 (12 V-55/60 W).

side light:

bulb type: W5W (12 V-4 W).

### ELECTRICAL CONTROLS ON HANDLEBARS:

#### TURN SIGNALS:

bulb type: W16W (12 V-16 W).

Horn.

Brake light switches.

Battery, 12 V-10 Ah.

Alternator 12 V-520 W.

ELECTRONIC VOLTAGE REGULATOR, protected by a 30 A fuse near the battery.

STARTER MOTOR, 12 V-0.7 kW.

### TAIL LIGHT AND BRAKE LIGHT:

bulb type: HD P5/21 W-12 V.

Number plate light:

bulb type: W5W (12 V-5 W).



## Notes

To replace the bulbs, refer to the "Changing the bulbs" paragraph, page 51.

## Fuses

The main fusebox is located under the seat in the electrical compartment (fig. 62).

The fuses are accessed by removing the cover (1), which shows the ampere ratings and mounting locations.

There are 7 fuses in the electrical system and these are located inside the fusebox.

The 30 A fuse (2) on the side of the fusebox (fig. 63) protects the electronic voltage regulator.

To access this fuse, remove the protective cap (3).

A blown fuse can be identified by a broken filament (4, fig. 64).



## Important

To avoid possible short circuits, switch the ignition key to OFF before renewing a fuse.



## Warning

Never use a fuse with a rating other than that specified. Failure to observe this rule may damage the electric system or even cause fire.

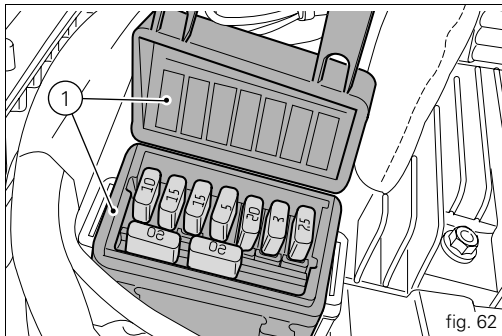

fig. 62

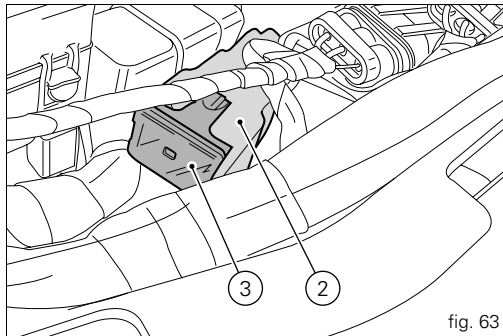

fig. 63

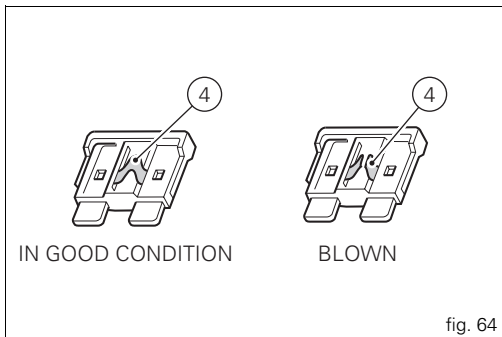

fig. 64

## Key to the electrical system / injection system diagram

- 1) RH handlebar switch
- 2) Transponder antenna
- 3) Key switch
- 4) Fusebox
- 5) Starter motor
- 6) Starter contactor
- 7) Battery
- 8) Master fuse (main fuse)
- 9) Regulator
- 10) Alternator
- 11) Rear right-turn signal
- 12) Tail light
- 13) Rear left-turn signal
- 14) Number plate light
- 15) Fuel tank
- 16) Charger connection
- 17) Self-diagnosis connection
- 18) Speed sensor
- 19) Sidestand switch
- 20) Lambda sensor
- 21) Horizontal cylinder coil
- 22) Vertical cylinder coil
- 23) Horizontal cylinder spark plug 1
- 24) Horizontal cylinder spark plug 2
- 25) Vertical cylinder spark plug 1
- 26) Vertical cylinder spark plug 2
- 27) Stepper motor
- 28) Horizontal cylinder injector
- 29) Vertical cylinder injector
- 30) Throttle position sensor
- 31) Rpm/timing sensor
- 32) ECU oil temperature sensor
- 33) Electronic Control Unit
- 34) Neutral switch
- 35) Oil pressure switch
- 36) Rear brake light switch
- 37) Front brake light switch
- 38) Clutch switch
- 39) Instrument panel oil temperature sensor
- 40) LH handlebar switch
- 41) Air temperature/pressure sensor
- 42) Instrumentation (instrument panel)
- 43) Front left turn signal
- 44) Horn 1
- 45) Headlight
- 46) Front right turn signal
- 47) Injection relay
- 48) Lights relay
- 49) Horn 2

## Wire colour code

B Blue  
W White  
V Violet  
Bk Black  
Y Yellow  
R Red  
Lb Light blue  
Gr Grey  
G Green  
Bn Brown  
O Orange  
P Pink

## KEY TO FUSEBOX

Pos.	Users	Val.
1	Key on, starter contactor, lambda	10 A
2	Side light, high beam/low beam headlight	15 A
3	Brake light, horn, flasher	15 A
4	Instrument panel	5 A
5	Injection (pump injector coils)	20 A
6	Engine Electronic Control Unit	5 A
7	Charger	7.5 A



## Notes

The electrical system wiring diagram is at the end of this manual.



## Routine maintenance record

KM	NAME OF DUCATI SERVICE	MILEAGE	DATE
1,000			
12,000			
24,000			
36,000			
48,000			
60,000			

# For United States of America Version Only

## Reporting of safety defects

If you believe that your vehicle has a defect which could cause a crash or could cause injury or death, you should immediately inform the National Highway Traffic Safety Administration (NHTSA) in addition to notifying Ducati North America. If NHTSA receives similar complaints, it may open an investigation, and if it finds that a safety defect exists in a group of vehicles, it may order a recall and remedy campaign. However, NHTSA cannot become involved in individual problems between you, your dealer, or Ducati North America. To contact NHTSA, you may either call the Auto Safety Hotline toll-free at 1-800-424-9393 (or 366-0123 in Washington, D.C. area) or write to: NHTSA, 1200 New Jersey Avenue SE W43-488, Washington, D.C. 20590. You can also obtain other information about motor vehicle safety from the Hotline.

## Safety warnings

Traffic Rules vary from jurisdiction to jurisdiction. Know the regulations in your jurisdiction before riding this motorcycle.



### Warning

This motorcycle is designed and intended for use on streets and other smooth, paved areas only. Do not use this motorcycle on unpaved surfaces. Such use could lead to upset or other accident.

## Noise emission warranty

Ducati Motor S.p.A. warrants that this exhaust system, at the time of sale, meets all applicable U.S. EPA Federal noise standards. This warranty extends to the first person who buys this exhaust system for purposes other than resale, and to all subsequent buyers. Warranty claims should be directed to: Ducati North America, 10443 Bandlely Drive, Cupertino, California, 95014 Tel: 001.408.253.0499 - Fax: 001.408.253.4099.

## Noise and exhaust emission control system information

### Source of Emissions

The combustion process produces carbon monoxide and hydrocarbons. Control of hydrocarbons is very important because under certain conditions, they react to form photochemical smog when subjected to sunlight.

Carbon monoxide does not react in the same way, but is toxic. Ducati utilizes lean carburetor settings and other systems to reduce carbon monoxide and hydrocarbons.

## Exhaust Emission Control System

The Exhaust Emission Control System is composed of lean carburetor settings, and no adjustments should be made except idle speed adjustments with the throttle stop screw. The Exhaust Emission Control System is separate from the crankcase emission control system.

## Crankcase Emission Control System

The engine is equipped with a closed crankcase system to prevent discharging crankcase emissions into the atmosphere. Blow-by gas is returned to the combustion chamber through the air cleaner and the throttle body.

## Evaporative Emission Control System

California motorcycles are equipped with an evaporative emission control system which consists of a charcoal canister and associated piping. This system prevents the escape of fuel vapors from the throttle body and fuel tank.

## Tampering warning

Tampering with Noise Control System Prohibited.

Federal Law prohibits the following acts or causing thereof:

(1) the removal or rendering inoperative by any person, other than for purposes of maintenance, repair, or replacement, of any device or element of design incorporated into any new

vehicle for the purpose of noise control prior to its sale or delivery to the ultimate purchaser or while it is in use; or (2) the use of the vehicle after such device or element of design has been removed or rendered inoperative by any person.

Among those acts presumed to constitute tampering are the acts listed below:

- (1) Removal of, or puncturing the muffler, baffles, header pipes or any other component which conducts exhaust gases.
- (2) Removal or puncturing of any part of the intake system.
- (3) Lack of proper maintenance.
- (4) Replacing any moving part of the vehicle, or parts of the exhaust or intake system, with parts other than those specified by the manufacturer.

This product should be checked for repair or replacement if the motorcycle noise has increased significantly through use. Otherwise, the owner may become subject to penalties under state and local ordinances.

## Problems that may affect motorcycle emissions

If you are aware of any of the following symptoms, have the vehicle inspected and repaired by your local Ducati dealer.

Symptoms:

Hard starting or stalling after starting.

Rough idle.

Misfiring or backfiring during acceleration.

After-burning (backfiring).

Poor performance (driveability) and poor economy.

## Riding safety

The points given below are applicable for every day motorcycle use and should be carefully observed for safe and effective vehicle operation.

A motorcycle does not provide the impact protection of an automobile, so defensive riding in addition to wearing protective apparel is extremely important.

Do not let protective apparel give you a false sense of security.

Before changing lanes, look over your shoulder to make sure the way is clear. Do not rely solely on the rear view mirror; you may misjudge a vehicle's distance and speed, or you may not see it at all.

When going up steep slopes, shift to a lower gear so that there is plenty of power to spare rather than overloading the engine.

When applying the brakes, use both the front and rear brakes. Applying only one brake for sudden braking may cause the motorcycle to skid and lose control.

When going down long slopes, control vehicle speed by closing the throttle. Use the front and rear brakes for auxiliary braking.

Riding at the proper rate of speed and avoiding unnecessarily fast acceleration are important not only for safety and low fuel consumption but also for long vehicle life and quieter operation.

When riding in wet conditions or on loose roadway surfaces, the ability to maneuver will be reduced. All of your actions should be smooth under these conditions. Sudden acceleration, braking or turning may cause loss of control.

When the roadway is wet, rely more on the throttle to control vehicle speed and less on the front and rear brakes.

The throttle should also be used judiciously to avoid skidding the rear wheel from too rapid acceleration or deceleration.

On rough roads, exercise caution, slow down, and grip the fuel tank with your knees for better stability.

When quick acceleration is necessary as in passing, shift to a lower gear to obtain the necessary power.

Do not down shift at too high an r.p.m. to avoid damage to the engine from overrevving.

Avoiding unnecessary weaving is important to the safety of both the rider and other motorists.

Do not exceed the legal speed limit or drive too fast for existing conditions. High speed increases the influence of any condition affecting stability and the loss of control.

Operate motorcycle only at moderate speed and out of traffic until you have become thoroughly familiar with its operation and handling characteristics under all conditions. This is a very high performance motorcycle, designed and intended for use by experienced careful riders only!

A new motorcycle must be operated according to a special break-in procedure (see Running in recommendations).



### Warning

Before starting engine, check for proper operation of brake, clutch, shifter, throttle controls, correct fuel and oil supply.

Gasoline is extremely flammable and is explosive under certain conditions. Refuell in a well ventilated area with the engine stopped. Do not smoke or allow open flames or sparks when refuelling or servicing the fuel system. Always close the fuel petcock when the engine is not running to prevent flooding of the throttle body. Do not overfill fuel tank (see instructions page 41).

Motorcycle exhaust contains poisonous carbon monoxide gas. Do not inhale exhaust gases and never run the engine in a closed garage or confined area.

Use only Ducati approved parts and accessories.

This motorcycle was not intended to be equipped with a sidecar or to be used to tow any trailer or other vehicle.

Ducati does not manufacture sidecars or trailers and cannot predict the effects of such accessories on handling or stability, but can only warn that the effects will be adverse and any damage to motorcycle components caused by the use of such accessories will not be remedied under warranty.



## Warning

Do not ride the motorcycle with helmets attached to the hook; the helmets could cause an accident by distracting the operator or interfering with normal vehicle operation.

## Protective apparel

Always wear a helmet. Most motorcycle accident fatalities are due to head injuries.

For safety eye protection, gloves, and high top, sturdy boots should also be worn.

The exhaust system becomes very hot during operation, never touch the exhaust system. Wear clothing that fully covers your legs. Do not wear loose clothing which could catch on the control levers, footrests, wheels, or chain. Any amount of alcohol will significantly interfere with your ability to safely operate your motorcycle. Don't drink and ride.

## Vehicle identification number (VIN)

Every Ducati motorcycle is identified by two identification numbers (see page 9). Fig. A specifically shows the frame identification numbers.

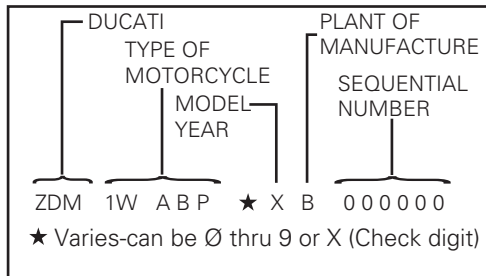
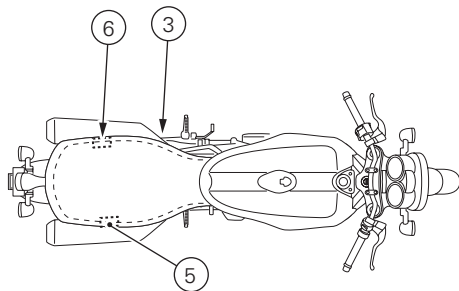
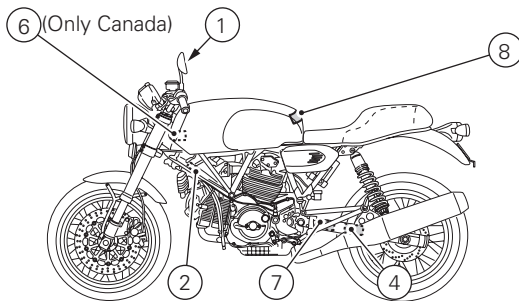
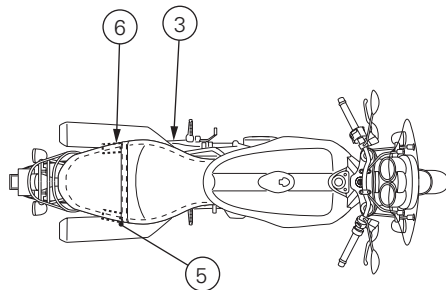
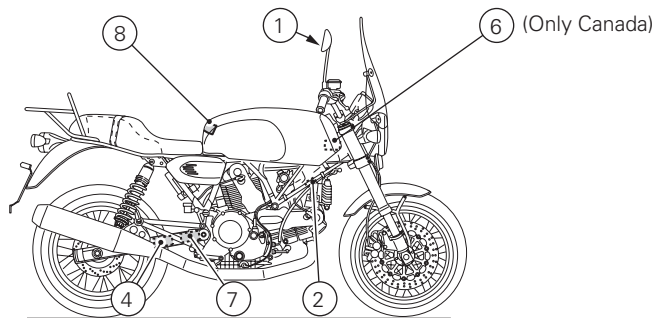

fig. A

# Label location (fig. B)

GT 1000





OBJECT IN MIRROR ARE CLOSER THAN THEY APPEAR

1

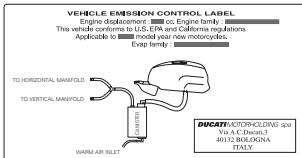

2

HELMET HOLDER UNDER THE SEAT

3

Tensione catena (in italiano) laterale (con escursione verso l'alto)  
 Chain Tension Adjustment (in side stand) with upward track



4

**MOTORCYCLE NOISE EMISSION CONTROL INFORMATION**

THIS xxxxx xxxxxxxxxxxx MOTORCYCLE xxxxxxxxxxxxxxxxxxxx000001  
 MEETS EPA NOISE EMISSION REQUIREMENTS OF xx dB(A) AT xxxxx RPM BY THE  
 FEDERAL TEST PROCEDURE.  
 MODIFICATIONS WHICH CAUSE THIS MOTORCYCLE TO EXCEED FEDERAL NOISE  
 STANDARDS ARE PROHIBITED BY FEDERAL LAW.  
 SEE OWNER'S MANUAL

432.1.xxx.1A

5

MANUFACTURED BY / FABRIQUÉ PAR: **DUCATI MOTORHOLDING spa**  
 TYPE OF VEHICLE / TYPE DE VÉHICULE: **MC** DATE: **xx/xxxx**  
 GVWR / PNBV: **x x x KG** VIN / NIV: **ZDMxxxxxxxx000001**

GAWR PBBE KG	TIRE/PNEU - DIMENSION - RIM/JANTE	COLD INFL. PRESS. PRESS. DE GONFL. A FROID PSI/LPG KPA
xxxx	x x x/x x Zr17 MT x x x x	xxx xxx
xxxx	x x x/x x Zr17 MT x x x x	xxx xxx

THIS VEHICLE CONFORMS TO ALL APPLICABLE STANDARDS PRESCRIBED UNDER THE CANADIAN  
 MOTOR VEHICLE SAFETY REGULATIONS IN EFFECT ON THE DATE OF MANUFACTURE.  
 CE VÉHICULE EST CONFORME À TOUTES LES NORMES QUI LUI SONT APPLICABLES EN VERTU DU  
 RÈGLEMENT SUR LA SÉCURITÉ DES VÉHICULES AUTOMOBILES DU CANADA EN VIGUEUR À LA  
 DATE DE SA FABRICATION.

432.1.xxx.1F

6 (Only Canada)

Manufactured by: **DUCATI MOTORHOLDING spa** DATE: **XX/XXXX**  
 GVWR: xxx Lbs (xxx kg)  
 GAWR F: xxx Lbs (xxx kg) with xxxxx ZR tire, xxxxxxxx rim at xxx PSI cold  
 GAWR R: xxx Lbs (xxx kg) with xxxxxZR tire, xxxxxxxx rim at xxx PSI cold  
 This vehicle conforms to all applicable Federal Motor Vehicle Standards in effect on the  
 date of manufacture shown above. Type classification: Motorcycle  
 Vehicle I.D. No. **ZDMXXXXXXXXXXXXXX** 432.1.xxx.1B

6

**VEHICLE EMISSION CONTROL INFORMATION**

Engine displacement: xxx cc  
 Engine family: xxxxxx  
 Engine exhaust control system:  
 SFI, 2 TWC and 1 HO2S  
 Evap family: xxxxxxxx  
 Permission family: xxxxxxxxxx

THIS VEHICLE CONFORMS TO U.S. EPA AND  
 CALIFORNIA REGULATIONS APPLICABLE TO 20xx  
 MODEL YEAR NEW MOTORCYCLES AND IS  
 CERTIFIED TO 0.8 HC+NOx G/KM ENGINE FAMILY  
 EXHAUST EMISSION STANDARD IN CALIFORNIA

**ENGINE TUNEUP SPECIFICATIONS**

ITEM	SPECIFICATIONS	INSTRUCTIONS
IGNITION TIMING	x°bTDC at idle speed	No adjustments
IDLE SPEED (RPM)	xxxx ± xxx	No adjustments
IDLE MIXTURE	Opening x.xx - x.xx mm	No adjustments
VALVE CLEARANCE (in & ex)	Closing x.xx - x.xx mm	See Service Manual

SPARK PLUG: xxxxxxxxxxxxxxxxxxxxxxxxx  
 SPARK PLUG GAP (mm): x.x - x.x mm  
**DUCATI MOTORHOLDING spa** - Bologna - Italy  
 Importer: **DUCATI** North America Inc. - Cupertino - California 432.1.xxx.1C

7

**CAUTION**

NEVER FILL TANK SO FUEL LEVEL RISES INTO FILLER  
 NECK. IF TANK IS OVERFILLED, HEAT MAY CAUSE  
 FUEL TO EXPAND AND FLOW INTO EVAPORATIVE  
 EMISSION CONTROL SYSTEM RESULTING IN HARD  
 STARTING AND ENGINE HESITATION.

8



## California evaporation emission system

This system consists of (fig. C):

- 1) Warm air inlet.
- 2) Canister.
- 3) Dell'Orto jet.
- 4) Intake manifolds.
- 5) Breather pipe.
- 6) Fuel tank.

### Important

In the event of fuel system malfunction, contact Ducati's authorized Service Centres.

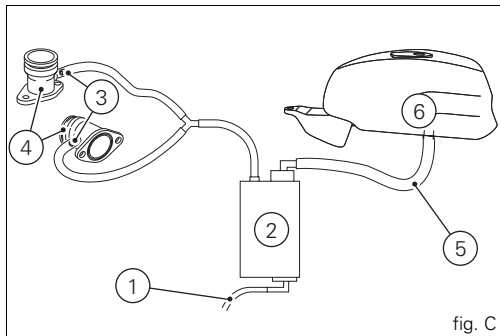

## Ducati limited warranty on emission control system

Ducati North America, Inc., 10443 Bandle Drive Cupertino, California, 95014 warrants that each new 1998 and later Ducati motorcycle, that includes as standard equipment a headlight, tail-light and stoplight, and is street legal:

A) is designed, built and equipped so as to conform at the time of initial retail purchase with all applicable regulations of the United States Environmental Protection Agency, and the California Air Resources Board; and  
 B) is free from defects in material and workmanship which cause such motorcycle to fail to conform with applicable regulations of the United States Environmental Protection Agency or the California Air Resources Board for a period of use of 30,000 kilometers (18,641 miles), or 5 (five) years from the date of initial retail delivery, whichever first occurs.

### I. Coverage

Warranty defects shall be remedied during customary business hours at any authorized Ducati motorcycle dealer located within the United States of America in compliance with the Clean Air Act and applicable regulations of the United States Environmental Protection Agency and the California Air Resources Board. Any part or parts replaced under this warranty shall become the property of Ducati. In the state of California only, emissions related warranted parts are specifically defined by that state's Emissions Warranty Parts List. These warranted parts are: carburetor and internal parts; intake manifold; fuel tank, fuel injection system; spark advance mechanism; crankcase breather; air cutoff valves; fuel tank cap for evaporative emission controlled vehicles; oil filler cap; pressure control valve;

fuel/vapor separator; canister; igniters; breaker governors; ignition coils; ignition wires; ignition points, condensers, and spark plugs if failure occurs prior to the first scheduled replacement, and hoses, clamps, fittings and tubing used directly in these parts. Since emission related parts may vary from model to model, certain models may not contain all of these parts and certain models may contain functionally equivalent parts.

In the state of California only, Emission Control System emergency repairs, as provided for in the California Administrative Code, may be performed by other than an authorized Ducati dealer. An emergency situation occurs when an authorized Ducati dealer is not reasonably available, a part is not available within 30 days, or a repair is not complete within 30 days. Any replacement part can be used in an emergency repair. Ducati will reimburse the owner for the expenses, including diagnosis, not to exceed Ducati's suggested retail price for all warranted parts replaced and labor charges based on Ducati's recommended time allowance for the warranty repair and the geographically appropriate hourly labor rate. The owner may be required to keep receipts and failed parts in order to receive compensation.

## II. Limitations

This Emission Control System Warranty shall not cover any of the following:

- A. Repair or replacement required as a result of
- (1) accident,
  - (2) misuse,
  - (3) repairs improperly performed or replacements improperly installed,

(4) use of replacement parts or accessories not conforming to Ducati specifications which adversely affect performance and/or

(5) use in competitive racing or related events.

B. Inspections, replacement of parts and other services and adjustments required for routine maintenance.

C. Any motorcycle on which odometer mileage has been changed so that actual mileage cannot be readily determined.

## III. Limited liability

A. The liability of Ducati under this Emission Control Systems Warranty is limited solely to the remedying of defects in material or workmanship by an authorized Ducati motorcycle dealer at its place of business during customary business hours. This warranty does not cover inconvenience or loss of use of the motorcycle or transportation of the motorcycle to or from the Ducati dealer. Ducati shall not be liable for any other expenses, loss or damage, whether direct, incidental, consequential or exemplary arising in connection with the sale or use of or inability to use the Ducati motorcycle for any purpose. Some states do not allow the exclusion or limitation of any incidental or consequential damages, so the above limitations may not apply to you.

B. No express emission control system warranty is given by Ducati except as specifically set forth herein. Any emission control system warranty implied by law, including any warranty of merchantability or fitness for a particular purpose, is limited to the express emission control systems warranty terms stated in this warranty. The foregoing statements of warranty are exclusive and in lieu of all other remedies.

Some states do not allow limitations on how long an implied warranty lasts so the above limitation may not apply to you.  
C. No dealer is authorized to modify this Ducati Limited Emission Control Systems Warranty.

#### IV. Legal rights

This warranty gives you specific legal rights, and you may also have other rights which vary from state to state.

V. This warranty is in addition to the Ducati limited motorcycle warranty.

#### VI. Additional information

Any replacement part that is equivalent in performance and durability may be used in the performance of any maintenance or repairs. However, Ducati is not liable for these parts. The owner is responsible for the performance of all required maintenance. Such maintenance may be performed at a service establishment or by any individual. The warranty period begins on the date the motorcycle is delivered to an ultimate purchaser.

Ducati North America, Inc.  
10443 Bandle Drive  
Cupertino, California, 95014  
Tel: 001.408.253.0499  
Fax: 001.408.253.4099  
E-mail: [customerservice@ducatiusa.com](mailto:customerservice@ducatiusa.com)  
Web site: [www.ducatiusa.com](http://www.ducatiusa.com)

# Routine maintenance record

KM	MI	DUCATI SERVICE NAME	MILEAGE	DATE
1,000	600			
12,000	7,500			
24,000	15,000			
36,000	22,500			
48,000	30,000			
60,000	37,500			

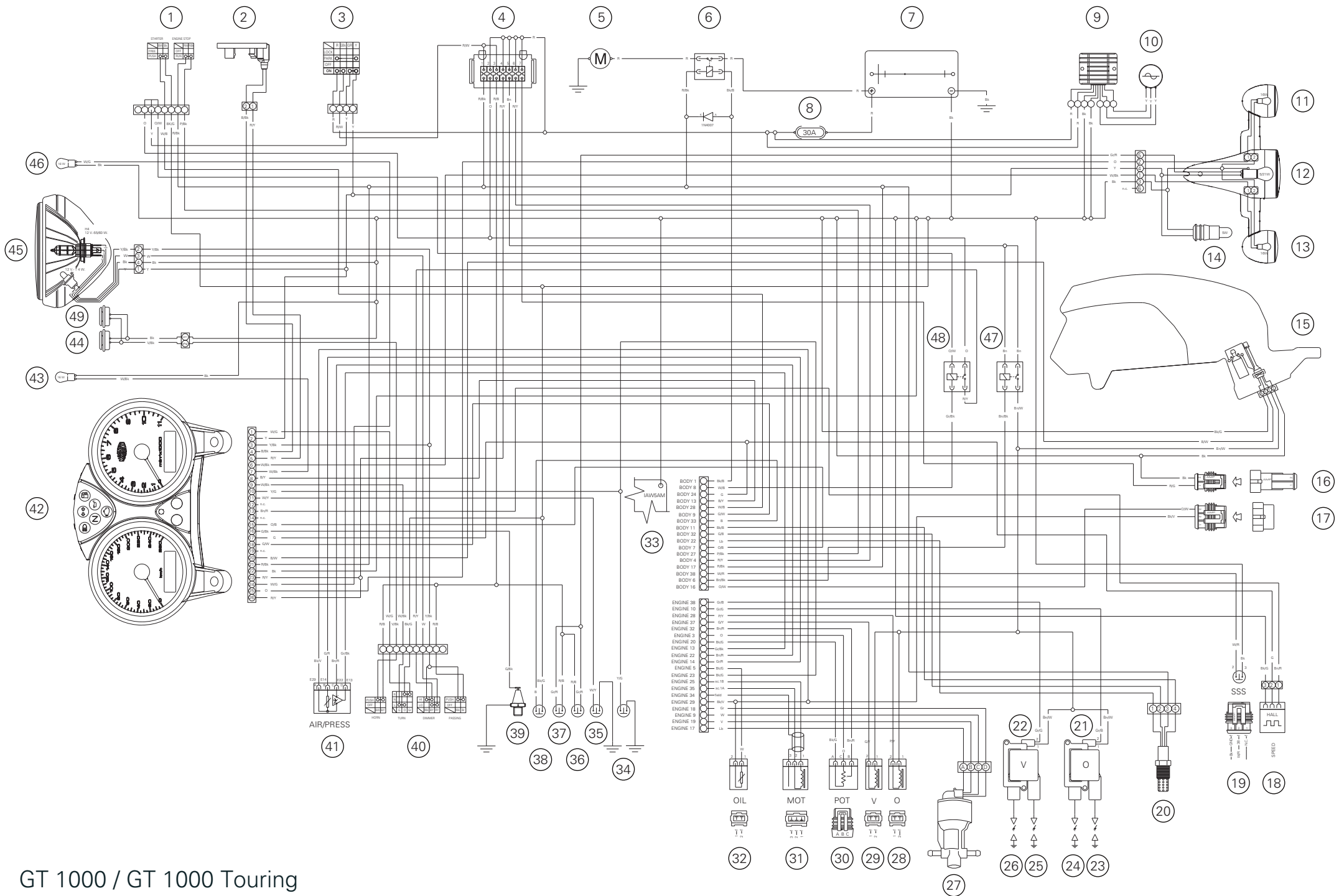

GT 1000 / GT 1000 Touring

Stampato 07/2009

Cod. 913.7.166.1B

Ducati Motor Holding spa  
[www.ducati.com](http://www.ducati.com)

Via Cavalieri Ducati, 3  
40132 Bologna, Italia  
Tel. +39 051 6413111  
Fax +39 051 406580